

Matthew Deeb
mattdeeb@hotmail.com
0212612592

'Live and Work Infill'

Master Thesis Explanatory Document / David Chaplin

Unitec Institute of Technology / 2010

ABSTRACT

The aim of this proposal, is to develop a building design for an internationally acclaimed photographer and a local architect, to 'live and work' within a service lane located in Auckland CBD. The project focuses on the transformation of a rundown service lane into an aesthetically pleasing, functional and livable infill; dealing with site confines and restraints, shapes the development into a 'form that works'. Research has helped to develop spatial arrangements and structural tectonics, producing exciting new living arrangements and providing inhabitants with an opportunity to recognise and appreciate how the space they inhabit, is constructed.

The project covers the architectural question and outline, site analysis, the design process and final design proposal.

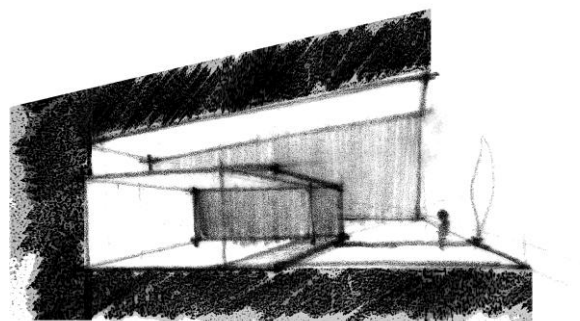

CONTENTS

1.0 INTRODUCTION	1
1.1 RESEARCH QUESTION	1
1.2 RESEARCH OUTLINE	1
2.0 CURRENT STATE OF KNOWLEDGE	4
2.1 SPATIAL QUALITY AND MAXIMISATION	4
2.2 FORMAL INSPIRATION	7
2.3 EXPLOITATION OF NEIGHBOURING AIRSPACE	8
2.4 STRUCTURAL TECTONICS	9
3.0 METHODOLOGICAL APPROACH OF THE PROJECT	11
4.0 PROJECT DEVELOPMENT	12
4.1 CLIENT BRIEFS / PROGRAMME	12
4.2 CLIENT SPATIAL REQUIREMENTS	14
4.3 SITE SELECTION	15
4.4 SELECTED SITE	16
4.5 SITE ANALYSIS	16
4.6 SITE SOLAR STUDIES	18
4.7 PROPERTY TITLE	19
4.7.1 DEPOSITED PLAN	20
4.8 SITE PHOTOS	21
4.9 SITE CONTEXT	22
4.9.1 LOCAL AUTHORITY INTENTIONS FOR HERITAGE BUILDINGS / SITES	22
5.0 ANALYSIS OF SITE EASEMENTS	23
5.1 EASEMENTS DEALT WITH BY DESIGN	23
5.2 LAND OWNERSHIP AND PROPERTY ASSUMPTIONS	24
5.3 SITE RESTRAINTS	25

6.0 DESIGN PROCESS	26
6.1 FUNCTIONAL ORGANISATION	26
6.2 SPATIAL LAYOUT	28
6.3 CONCEPT / FORM	30
6.4 STRUCTURAL SYSTEMS	31
6.5 SPINE AND FLOORS	32
6.6 MATERIALITY	33
7.0 CRITICAL APPRAISAL AND CONCLUSION	36
8.0 BIBLIOGRAPHY	38
9.0 APPENDEX	39
9.1 CONSULTANT LOG	39
9.2 CLIENT CONVERSATION LOG	41

LIST OF FIGURES

Figure 2.1.1: K. Associates s Infill House in Nipponbashi

Figure 2.1.2: Nipponbashi Floor plans

Figure 2.1.3: Atelier Bow-Wow's Residence and Workplace

Figure 2.1.4: Hadid's Office Infill Concept

Figure 2.2.1: TNA's Colour Concrete House

Figure 2.3.1: Melling's Wellington Residence and Office

Figure 2.3.2: Skybox Floor Plans

Figure 2.4.1: Wright's Johnson & Son Research Centre, Section, Wisconsin 1947

Figure 2.4.2: Wright's- Johnson Wax Administration building, Column Section, Racine, 1936-1939

Figure 2.4.3: Foster Associates, Glass Wall Detail and Section, England, 1974

Figure 4.3.1: Auckland Regional Map – Alggi Map Portal. Showing similar infill site locations

Figure 4.4.1: Aerial Photo of Site - Alggi Map Portal

Figure 4.5.1: Location Plan / Figure Ground – Alggi Map Portal

Figure 4.5.2: Site Map – Alggi Map Portal

Figure 4.5.3: Site Analysis Diagram. Showing compass axis, sun and prevailing wind

Figure 4.6.1: Site Model – Winter Morning

Figure 4.6.2: Site Model – Winter Evening

Figure 4.6.3: Site Model – Summer Morning

Figure 4.6.4: Site Model – Summer Evening

Figure 4.7.1: Property Title

Figure 4.7.2: Deposited Plan

Figure 4.8.1: Service Lane Photo

Figure 4.8.2: Site Model 1:500 Photo

Figure 5.3.2: Diagram of Lister Services, Access Points (Yellow) and Inspection Junctions (Red)

Figure 6.1.1: Sketch showing initial functional stack

Figure 6.1.2: Sketch showing a developed functional layout with gallery

Figure 6.1.3: Sketch showing a final functional organization with pedestrian right of way.

Figure 6.1.4: Sketch showing basic function organization.

Figure 6.2.1: Initial spatial arrangement with Core situated at back of site

Figure 6.2.2: Developed arrangement, centralizing core for a better distribution of light and circulation.

Figure 6.2.3: Axonometric view of developed arrangement

Figure 6.2.4: Final spatial arrangement with gallery space which is now a pedestrian right of way

Figure 6.3.1: Concept Development Sketches

Figure 6.4.1: Structural Development Model

Figure 6.5.1: Section Showing Hierarchy

Figure 6.5.2: Expressive Slab to Spine Concept Model

Figure 6.5.3: Sketch Detail of Tapered Slab to Spine

Figure 6.5.4: Entrance Sketch Showing Meeting of Spine to Slab

Figure 6.6.1: Conceptual Model Showing Materiality

1.0 INTRODUCTION

1.1 THE RESEARCH QUESTION

Can a rundown urban service lane in Auckland CBD be transformed into a functional, livable infill for a photographer and architect to live and work?

1.2 RESEARCH PROBLEM / OUTLINE

Urban cavities within Auckland CBD present an opportunity for the development of conscientious and contextually designed infill¹ buildings. This study explores the transformation of a rundown service lane site into an articulated, functional live and work space.

The key objectives of this project are to:

- Meet the live and work requirements of two clients – an architect and a photographer.
- Enhance the spatial experience through structural expression.
- Integrate sustainable systems.
- Explore whether this transformational development is a viable model for future infill in New Zealand.

MEETING THE BRIEF

The challenge this project presents is not only having to effectively meet the live and work requirements of the two clients (a photographer and his family and an architect and his wife) but having to do so in the confines of an inner city service lane, dictated by the site I have selected on Lorne Street.

Living in the city presents its own set of challenges when it comes to providing a suitable and desirable, client offering – one that satisfies both domestic and work requirements.

Key considerations need to be made in order to meet both client's requirements. These include the desire for low maintenance, cohesive domestic and commercial spaces; with access to entertainment, recreation and town services.² The selection of the site on Lorne Street meets the location considerations. For example; from the occupant's residence there are views of Albert Park to the east and parts of Queen Street to the west. Surrounding amenities exist such as; film and theatre, art galleries, convenience food store, night life and a supermarket located only one kilometre away on

¹ Infill: "Is an industry term for the development of small-scale parcels of land within built-up areas" – www.Dictionary.com

² *North Shore City Council, Good Solutions Guide, 2005, 6*

Quay Street. The central location allows the occupants to easily access the Auckland motorways and venture north or south. Avoiding the cities peak hour traffic, will ensure the two families can be at any function or place in Auckland in around ten to fifteen minutes. Parking can be made possible by renting space from the neighbouring building car park (refer to figure 5.2.3).

The development itself meets the more specific spatial live and work requirements. For example; outdoor spaces such as, roof gardens and terraces are created which help relax the occupant, making them feel afloat and enhancing their connection with nature³ – a scarce inner city living quality in New Zealand. The infill spatial arrangement attempts to solve the effects of commercial activity on domestic social activity in a live and work situation. The idea is that the workplace itself will become a nicer place, “more like a home, where life is carried on and not banished for eight hours. Workers can go home casually for lunch, run errands, work halftime and spend half the day at home”.⁴ “It is only where dwellings are amongst other functions or building types that the personal quality of the households and house-building activities gives energy to the workshops, offices and services”.⁵ “When people have their own homes among shops, workplaces, school, services, universities, these places are enhanced by the vitality that is natural to their homes. They extend themselves to make it personal and comfortable”.⁶

ENHANCING THE SPATIAL EXPERIENCE

Maximising the use of space within the confined area presented by the Lorne Street service lane is a key challenge to this project. In essence the aim is to create a machine for living and working in which integrates not only with its site but with itself - from the structured facade to the internal cabinetry – creating a built-in experience. The design process looks at the functional organisation of spaces and establishes the most efficient arrangement of this space. Research into structural tectonics⁷ further assists the enhancement of the developed spaces – providing the occupant with an understanding of how the building they inhabit is constructed.

INTEGRATING SUSTAINABILITY

As a modern building, it is important to integrate sustainable systems. By its very nature city living offers a more sustainable approach to living. For example; “An apartment dweller who occupies less than 1000sq feet, has no lawn or very little to water, shares a heating system with his fellow tenants and uses public transportation, is far kinder to the environment than his counterpart in the suburbs who drive everywhere and live in a single dwelling on its own landscaped plot”⁸. Furthermore, “with

³ Kishi, W. (1992) “House in Nipponbashi”, 1

⁴ Alexander, C. (1977). “A Pattern Language Towns, Buildings, Construction”. New York, Oxford University, 53

⁵ Alexander, C. (1977). “A Pattern Language Towns, Buildings, Construction”. New York, Oxford University, 257

⁶ Alexander, C. (1977). “A Pattern Language Towns, Buildings, Construction”. New York, Oxford University, 257

⁷ Tectonics - “The art of assembling, shaping, or ornamenting materials and connections in construction” - www.Dictionary.com

⁸ Stang, A. (2005). “The Green House: New Directions in Sustainable Architecture”, New York, 19

recyclable resources, existing infrastructure, and density of suppliers, the city also turns out to be a potentially eco-friendly site for construction”.⁹

This project attempts to integrate sustainable building practices and features, as possible. Active systems include the use of a roof mounted heat pump for cooling and heating. While passive systems, such as, thermal massing help to maintain a comfortable internal temperature. If planted with sod or natural grasses the roof gardens could help to lower the buildings energy use by way of natural evaporation in summer and providing insulation in winter.¹⁰

A VIABLE MODEL?

Broadly, this project considers the benefits of urban densification and aims to provide a model for future service lane infill developments throughout New Zealand.

This technique of urban densification offers two key benefits. The first is that structures are built on land that has already been developed and not on pristine untouched earth.¹¹ This provides the opportunity to improve the city’s appearance and functionality. Secondly, it attempts to reduce urban sprawl.

Urban densification¹² through infill development in New Zealand is not as common, as it is abroad in places such as, London or Japan. However, locally, major New Zealand cities like Wellington and Auckland are addressing urban densification issues and have produced reports on this topic such as “Intensification and the District Plan - Issues and Options for Facilitating and Managing Intensive Residential Development”.¹³ Where there is urban infill development in New Zealand it is evident there are more examples on residential infill than commercial infill or mixed. Gerald Melling’s Skybox has proved to be a start to a type of mixed use infill development in this country (Precedent, see page 8).

A mixed-use infill development within a service lane is something that has not yet spawned in New Zealand. The hope is that this project will demonstrate that this type of infill development is viable. The benefit of which will be a revitalised outlook on apartment living, encouraging the creation of exciting reconfigurations of domestic space and redefining the ideal of modern space.

⁹ Stang, A. (2005). *“The Green House: New Directions in Sustainable Architecture”*, New York, 20

¹⁰ Stang, A. (2005). *“The Green House: New Directions in Sustainable Architecture”*, New York, 5

¹¹ Alexander, C. (1977). *“A Pattern Language Towns, Buildings, Construction”*. New York, Oxford University, 511

¹² *Urban Densification - Is the creation of higher residential densities in urban areas through infill development, redevelopment, and more compact new development – Auckland City Council, (2004) “Growth Strategy, Glossary and References”, 1*

¹³ 07 2010 The Broadsheet of the Auckland Branch of the New Zealand Institute of Architects, “Auckland Architecture: A field Guide”, 3 - 4

2.0 CURRENT STATE OF KNOWLEDGE

2.1 SPATIAL QUALITY AND MAXIMISATION

WARO KISHI + K.ASSOCIATES

HOUSE IN NIPPONBASHI / WORK AND LIVE INFIL / NANIWA-KU OSAKA 1992



Figure 2.1.1: K. Associates's Infill House in Nipponbashi

The architect's intentions of this project were to give new meaning to a roof garden. It is a great example of urban densification and utilisation of space.

The Nipponbashi work and live infill is situated on a street front site measuring 2.5 X 13m and takes full advantage of every square metre. The site area is 42sqm while the building area is more than twice this, at 112sqm. It incorporates outdoor open aired terraces, six metre high ceilings for living spaces while emphasising the "verticality of urban life".¹⁴ The floating living spaces separate the occupant from the "noise of the street".¹⁵

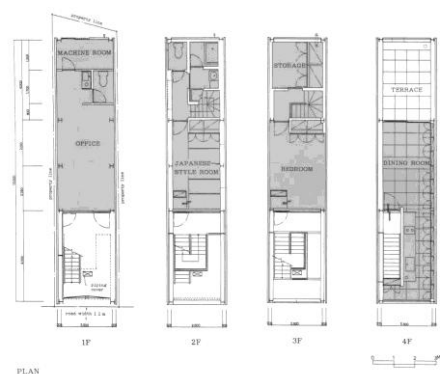

Figure 2.1.2: Nipponbashi's Floor Plans

This precedent reinvents the roof garden, which modern architecture abolished. By doing so it brings the observer closer to nature through an "elevated outdoor space that appears to be at ground level".¹⁶ The building allows the observer a privileged view and a unique sensation of being afloat.

¹⁴ Kishi, W. (1992) "House in Nipponbashi", 1

¹⁵ Kishi, W. (1992) "House in Nipponbashi", 1

¹⁶ Kishi, W. (1992) "House in Nipponbashi", 1

ATELIER BOW-WOW

HOUSE AND ATELIER / WORK AND LIVE / JAPAN

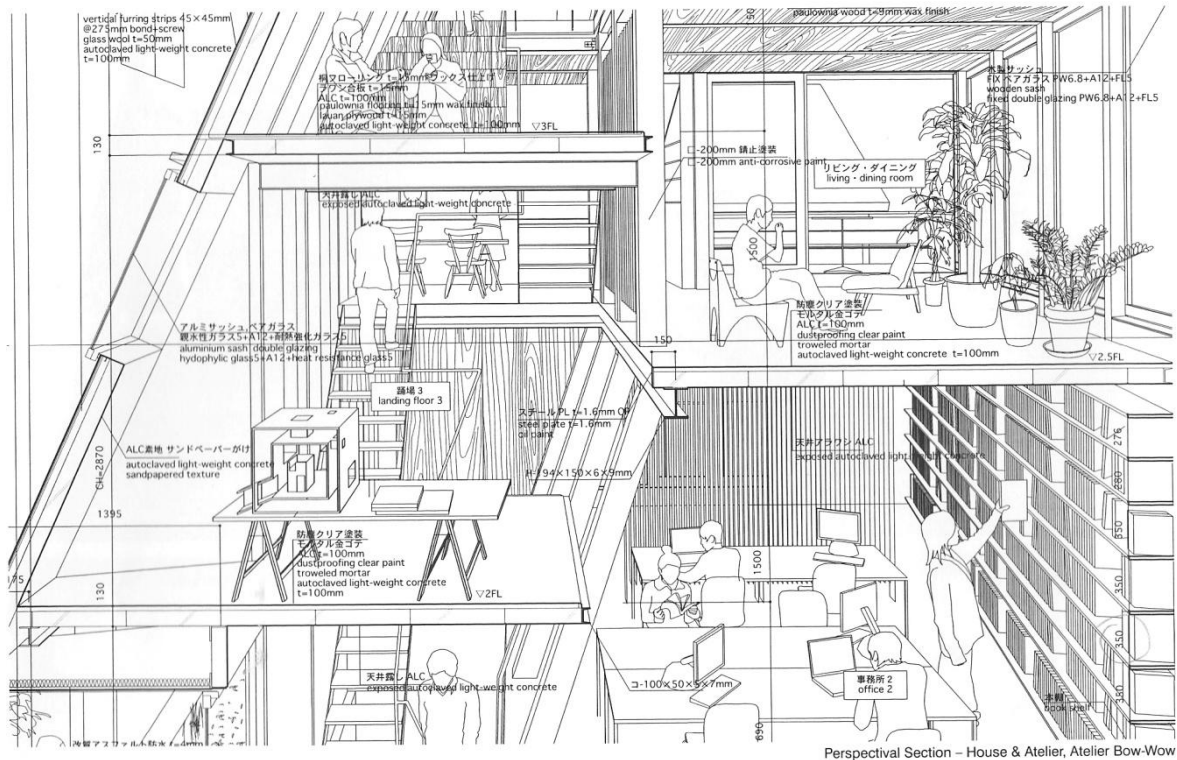

Figure 2.1.3: Atelier Bow-Wow's Residence and Workplace

Atelier Bow-Wow exploits every space of this live and work building, creating moments of spatial delight. "He teaches us that condensing back into smaller urban spaces isn't necessarily a bad thing as it creates an exciting re-imagining of internal space, reconstituting the ideal of domestic."¹⁷

Bow-wow is interested in the maximisation of space, as he attempts to simultaneously create building footprints which are two or three times as large, as the site area. So even though the site is small, the spaces created within it feel generous and delightful. His intentions are direct, in producing spaces that relate directly to his client's needs and does not rely on a gallery, as a flexible backdrop or dead space. "Why should the occupant have to buy new furniture?"¹⁸

¹⁷ Bow-Wow, A. (2010). "Auckland Architecture: A field Guide" "The Broadsheet of the Auckland Branch of the New Zealand Institute of Architects (July Issue): 3, 4.

¹⁸ Bow-Wow, A. (2010). "Auckland Architecture: A field Guide" "The Broadsheet of the Auckland Branch of the New Zealand Institute of Architects (July Issue): 3, 4.

ZAHA HADID

KURFURSTENDAM / OFFICE INFILL / GERMANY 1986

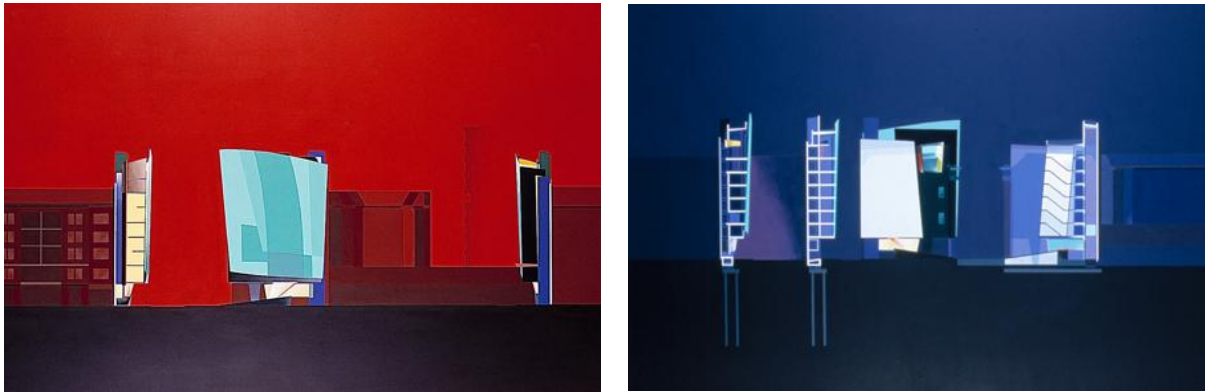

Figure 2.1.4: Hadid's Office Infill Concept

This precedent has the structural tectonics of that seen in Frank Lloyd Wright's 'Johnson Wax Building', with the use of a centralised core and cantilevered floors. However, of greater interest is the way it maximises the utilisation of space with the internal spaces being nearly 15 times the size of its site's area.

This building liberates the plan from the ground by utilising a ramp. A series of sandwiched panels make up the fundamentals for the arrangement of the floor plan, also characterised by the "constraints and limitations of the extremely narrow site (2.7 x 16 m)". The site area is 43.20sqm, while the building's area amounts to a staggering 820sqm. These spaces encompass offices on above levels with a roof top as an outdoor room. The office spaces are multi-use which can be easily rearranged and look out onto the street. "Horizontally, the sandwich of planes becomes the basis for the organisation of the floor plan, which establishes the separation of circulation and movement from the office spaces. Vertically, the sandwich of spaces establishes the distinction of the unique floor plan at ground level for the public entry from the cantilevered building overhead".¹⁹

¹⁹ Hadid, Z. (1986) *Office Building on KURFURSTENDAMM 70*, 1

2.2 FORMAL INSPIRATION

TNA ARCHITECTS / TOKYO

THE COLOUR CONCRETE HOUSE



Figure 2.2.1: TNA's Colour Concrete House

This infill example is formally inspiring and influential to this project.

The architects TNA start with a basic form then subtract certain volumes to create openings for windows, decks and entrances, according to the needs of the occupant. It has a simple aesthetic but one that is appealing, particularly the simple use of materials comprising a concrete and glass exterior, with a timber interior.

2.3 EXPLOITATION OF NEIGHBOURING AIRSPACE

GERALD MELLING

THE SKY BOX / WORK AND LIVE / WELLINGTON CITY 2002 / NEW ZEALAND



Figure 2.3.1: Melling's Wellington Residence and Office

This precedent shows the possibilities of air space exploitation.

A self supporting building straddles the commercial building below with its structure, while exploiting its air space like parasitic architecture.²⁰

"Situated near the heart of Wellington's creative Cuba St district, Skybox follows the notion of live/work/play in the same location.

The compact but spacious home combines a simplicity of material, clever detailing and a sense of humour".²¹

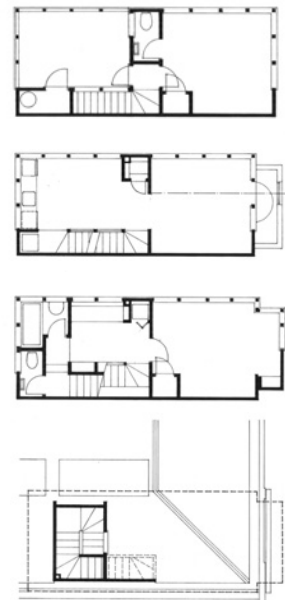

Figure 2.3.2: Skybox Floor Plans

²⁰ Walker, C. (2005). *Exquisite Apart : 100 Years of Architecture in New Zealand*. Auckland, N.Z, 136

²¹ Morse, M. (2002). "Skybox", *Home and Entertaining*, 56.

2.4 STRUCTURAL TECTONICS

FRANK LLOYD WRIGHT

The expression of structure and honesty to materials is something that is significant to this project, as it strengthens the structural integrity and helps to integrate itself into its existing context masonry. The structural expression or structural tectonics exposes the joints and junctions of the material connections enabling the viewer to appreciate the art of construction.

An inspirational structural system is seen Frank Lloyd Wright's Johnson and Son Research Centre. This building is made up of a cylindrical hollow service core from where "cantilevered platforms extend to embody the floors of the building".²² The hollow platforms integrate air ducts for air-conditioning, while the core comprises lavatories and elevators. The facade is stepped tiers of suspended glazing, similar to that of a curtain wall.

Further research into the expression of structure and structural arrangements come Wright's research tower or "pagoda", for the Johnson Wax building.²³ The tower is comprised of a central concrete spine and cantilevered floors. "The pagoda has its ultimate origin in the Indian stupa, the central spine which was seen, as an axis mundi or cosmic pillar, identified in Buddhist philosophy as the Tree of Enlightenment".²⁴

Figure 2.4.1: Wright's Johnson & Son Research Centre, Section, Wisconsin 1947

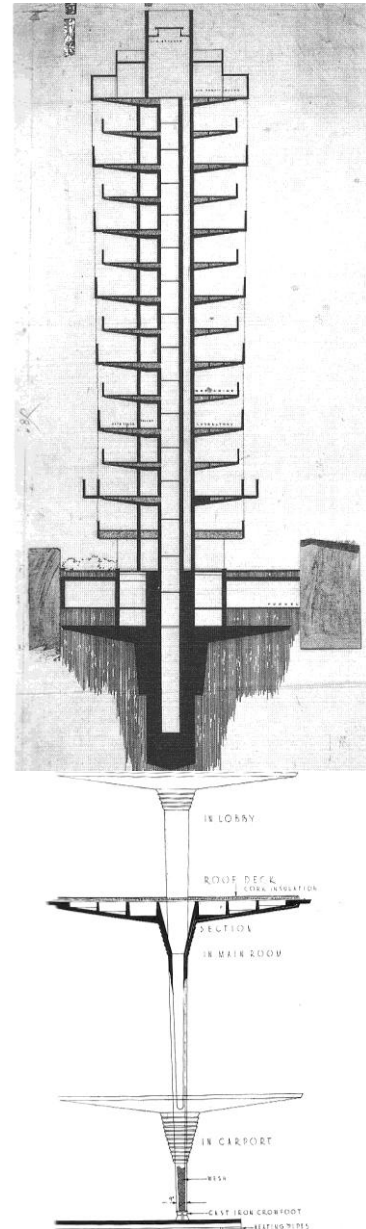

Figure 2.4.2: Wright's Johnson Wax Administration building, Column Section, Racine, 1936-1939

²² Frampton, K. (1995). *Studies In Tectonic Culture: The poetics of construction in nineteenth and twentieth century architecture*. Chicago, 259

²³ Frampton, K. (1995). *Studies In Tectonic Culture: The poetics of construction in nineteenth and twentieth century architecture*. Chicago, 113

²⁴ Frampton, K. (1995). *Studies In Tectonic Culture: The poetics of construction in nineteenth and twentieth century architecture*. Chicago, 113

FOSTER ASSOCIATES

TWIN SKIN FACADE

This is an example of an expressive curtain wall system made up of a suspended steel grate, infilled with glass and supported by brackets extending from the tapered floors.²⁵

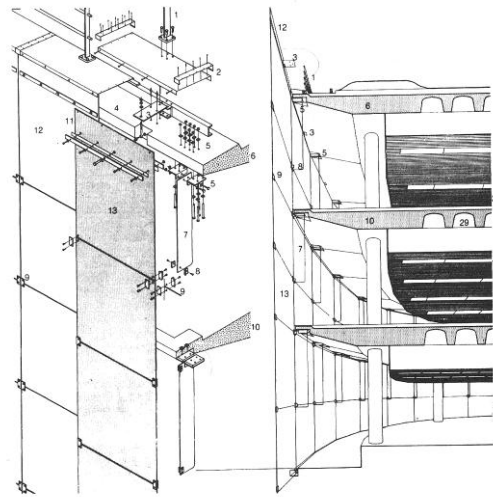

Figure 2.4.3: Foster Associates, Glass Wall Detail and Section, England, 1974

²⁵ Frampton, K. (1995). *Studies In Tectonic Culture: The poetics of construction in nineteenth and twentieth century architecture*. Chicago, 353

3.0 METHODOLOGICAL APPROACH OF THE PROJECT

- Develop a comprehensive architectural brief from client briefs, so that the size, capacity, outcome and program for this project are clear.
- Show the distribution of similar urban spaces that have potential for multiuse occupation within Auckland CBD.
- Select one such site and complete a comprehensive site survey and analysis, including initial sketch and photographic documentation, and addressing all the factors influencing construction on the site.
- Physical site model built to obtain a clear idea of the site and conduct a solar study.
- Develop a building design by firstly, developing analytical bubble diagrams of spatial elements and the relationship between them. Secondly, functional organisation to satisfy the client briefs, requiring design mainly in section which is essential due to the confined dimensions of the building area, to define level changes and solve problems which are difficult to evaluate on plan. These may help to see new spatial opportunities.
- Building form is generated through modelling and drawing so that it remains consistent with site restrictions and program.
- Design will be mainly hand drawn and accurate plans and final physical model produced at a scale of: 1:100.

4.0 PROJECT DEVELOPMENT

4.1 CLIENT BRIEFS FOR HYPOTHETICAL PROJECT

NATHANIEL.C LOCAL ARCHITECT BASED IN AUCKLAND

“Lots of natural light and a place to curl up and read in the sun

Two places to sleep that accommodate two people each and that are separate in some way from each other and eating, cooking and sitting spaces.

A single bathroom only but with which somehow separable WC and cunning double-entrance so it can be accessed from both the public side and bedroom.

Smart kitchen open to the sitting and eating spaces that is robust and designed for cooking not slickness – hanging implements etc – with a place for everything.

A small decompression space between outside and in – so that the sitting etc is not immediately visible from the front door, and there’s a place to take off coats, stack umbrellas.

A fluid plan that has a minimum of doors.

Plenty of bookshelves, wardrobes, storage integrated into fabric of building – perhaps no walls at all, only cabinetry (although the “verso” side of that cabinetry should be a good wall – robust, absolutely uninterrupted to facilitate good art hanging).

I don’t want to see power points, light switches or TVs.

No trims, skirtings or architraves placed on top of junctions in a typical kiwi fashion.

If in the city prefer to live at least a storey above the street, so preferred stack from ground up is cars – studio – apartment – roof garden; and if the site is right perhaps food/beverage/retail to street level.

Large more-or-less private (i.e. a skyscraper overlooking is ok but not an immediate neighbour) garden/terrace with proper trees either opening off sitting/eating space or/roof garden opening off a small study/reading room or both.

Studio large open space 100~200m², empty light and pale with something to conceal guts (print, copy, model gear, storage) and some part that can be made private for meetings. No reception.

Materials should not be expensive – I am happy with humble materials well treated so as to become very special²⁶.

²⁶ Nathaniel. C - Refer to Appendix for Client Log

NADAV.K INTERNATIONAL PHOTOGRAPHER CURRENTLY WORKING IN LONDON

"I would like to establish a house/office in Auckland city central where I can stay with my family and work from home. At the same time I want to be able to run my photography business from the site with the following in mind.

My studio needs to be at least 10m x 15m, better would be 10m x 23m shooting space, not necessarily day lit as I light most things. Height needs to be at least 4.5m. If an area was day lit this could be curtained off and used as a client area with sofa, chairs and a computer and possibly a small freestanding kitchen for serving food and drinks, this area would be OK at 6m x 4m, holding about 8 people comfortably, and carved out of the studio space. Separate there needs to be a hair, makeup and stylist room about the same size as client room.

I would like another store area for lights, cameras and stands etc-it should be off the main studio and be very secure and have a wide door to ceiling height. Bathroom should be spa like with large basin, shower and toilet.

My office and production area needs to have 4 stations to work at. This is where daylight would be great, very modern and few materials e.g. Oak and concrete. This is where most of my time is spent and should look beautiful and neat but understated. This is where all the printing is done, digital manipulation, phone calls meetings and most meals are eaten. My studio at the moment has a day lit area of 10m x 10m dedicated to this and it is ample. So an ideal situation would be storage cupboards on 3 sides including small kitchen and deep cupboards.

Then 2 or 3 long wide desks 6m x 1.5m for 4 computers 2 people one side of one desk and another two opposite. The other 2 surfaces would be for eating and meeting and laying out papers and large prints. Freestanding book shelves can be used to portion off an area, let's say for meeting e.g. Toilets needed here or could share with the studio. "DON'T UNDERESTIMATE MY STORAGE NEEDS"²⁷.

²⁷ Nadav. K - Refer to Appendix for Client Log

4.2 CLIENT SPATIAL REQUIREMENTS

NATHANIEL.C

<i>Work</i>	
Studio	100m ²
Meeting Room	20m ²
Storage	20m ²
Toilet	7m ²
<i>Live</i>	
Master Bedroom	15m ²
Kitchen/Dining	40m ²
Laundry	5m ²
Decomp / buffer space	6.5m ²
Bathroom	7m ²
Study/Reading /	15m ²
Roof-garden	30m ²

Total: 265.5m²

Circulation

Core 5 x 3.150 = 15.750m²

+15% of program : 695.8 + 15% = **800 m²**

NADAV.K

<i>Work</i>	
Studio + Storage	150m ²
Client meeting room	
Kitchenette/ eating area	
Toilet (spa like)	
Total	40m ²
Stylist Room	15m ²
Office +production area + Storage (bookshelves)	60m ²
<i>Live</i>	
Master Bedroom	15m ²
On-suite Bathroom	7m ²
Kids Bedrooms x2/3	30m ²
Bathroom	7m ²
Study / Kids TV room	15m ²
Storage	10m ²
Laundry	7m ²
Roof-garden + Outdoor Terrace	75m ²

Total: 439m²

4.3 SITE SELECTION



Figure 4.3.1: Auckland Regional Map – Alggi Map Portal. Showing similar infill site locations

4.4 SELECTED SITE

LORNE ST SITE



Figure 4.4.1: Aerial Photo of Site - Alggi Map Portal

4.5 SITE ANALYSIS



Figure 4.5.1: Location Plan / Figure Ground – Alggi Map Portal



Figure 4.5.2: Site Map – Alggi Map Portal

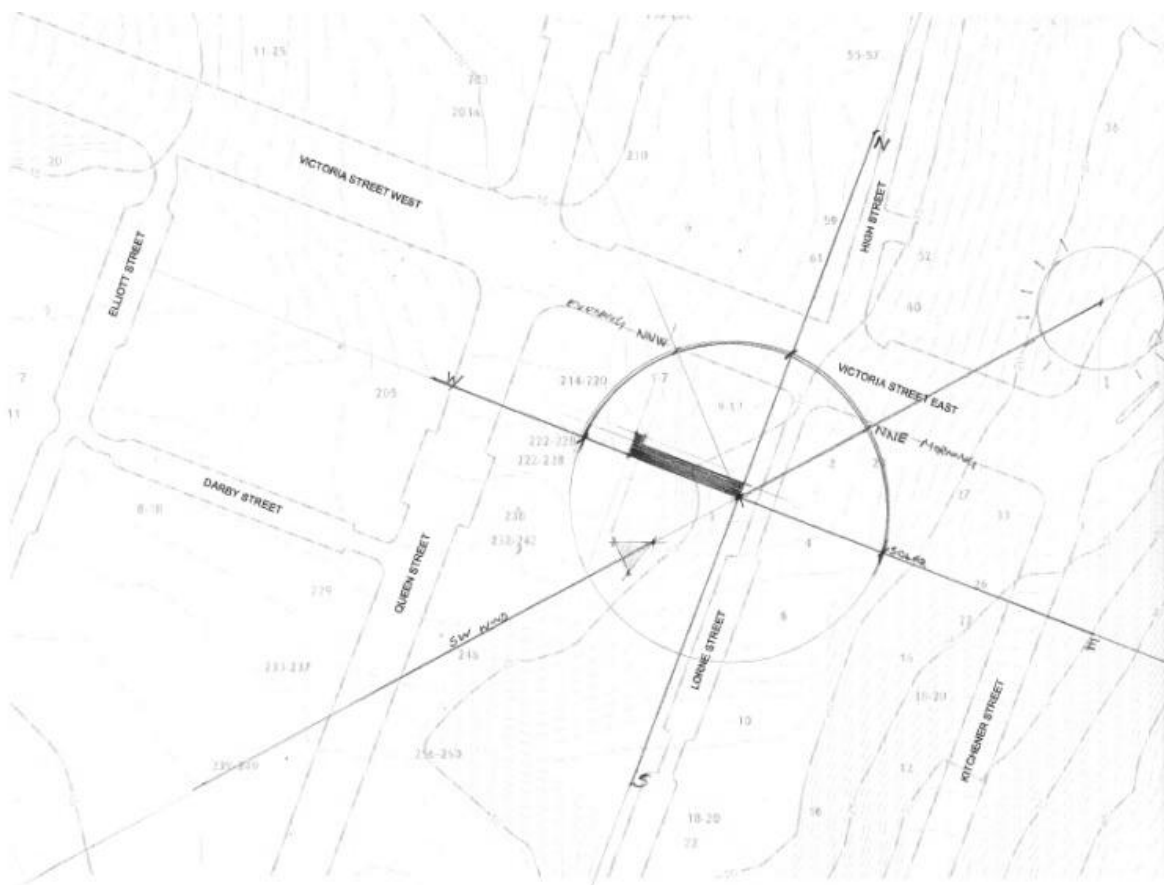

Figure 4.5.3: Site Analysis Diagram. Showing compass axis, sun and prevailing wind

4.6 SITE SOLAR STUDIES

Solar Studies is a good way to demonstrate approximate sun patterns throughout the day, in summer and winter seasons. For design purposes, the study suggests where the sunniest parts of the site are and will potentially inform the functional organisation of spaces, within the infill development. From these results it is possible to say that the appropriate stack should be commercial spaces situated lower to ground level, while residential spaces are to be raised to take advantage of natural light.

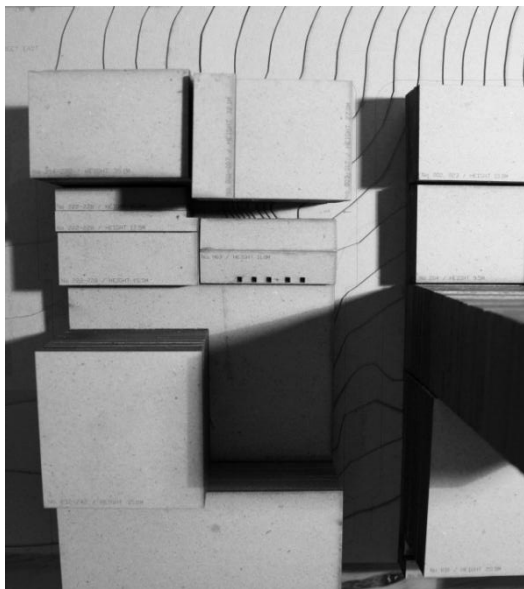

Figure 4.6.1: Site Model – Winter Morning

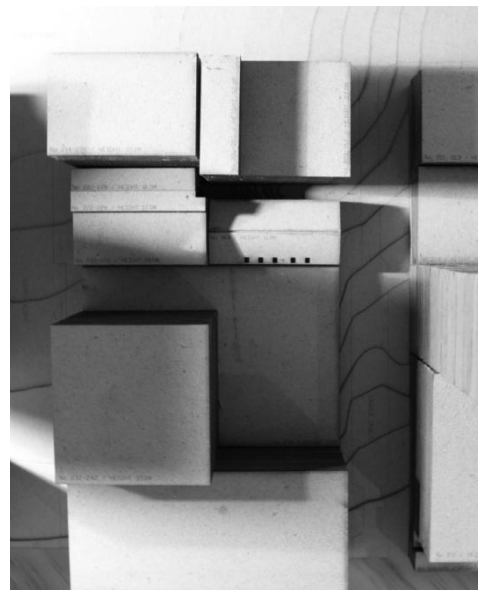

Figure 4.6.2: Site Model – Winter Evening

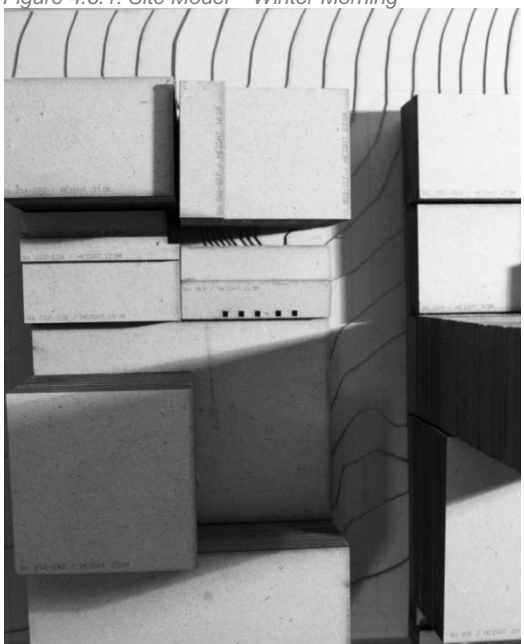

Figure 4.6.3: Site Model – Summer Morning

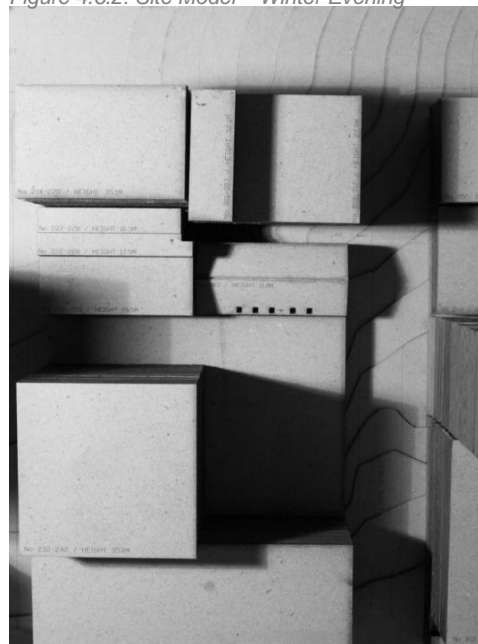

Figure 4.6.4: Site Model – Summer Evening

4.7 PROPERTY TITLE



	COMPUTER FREEHOLD REGISTER UNDER LAND TRANSFER ACT 1952	  R.W. Muir Registrar-General of Land
Identifier	NA121D/310	
Land Registration District	North Auckland	
Date Issued	14 June 1999	
Prior References		
NA24B/1304		
<hr/>		
Estate	Fee Simple	
Area	92 square metres more or less	
Legal Description	Lot 3 Deposited Plan 192157	
Proprietors		
Catherine Anne Spencer and Martin Berridge Spencer		
<hr/>		
Interests		
D175621.4 Mortgage to ASB Bank Limited - 25.7.1997 at 12.57 pm		
Subject to a pedestrian right of way over parts marked B,C, F, R, S and T and to a projection right over parts marked B and C on DP 192157 created by Transfer D177205.3 - 30.7.1997 at 3.42 pm		
Subject to a lightwell easement over parts marked H, K, P, Q and R, a right of way and services easement over parts marked A, B, C, D, F, H, I, K, N, P, Q, R, S and T, and a light easement over parts marked A, B, C, D, F, H, I, K, N, S and T on DP 192157 created by Transfer 6127583.1 - 26.8.2004 at 9:00 am		
<hr/>		
<i>Transaction Id</i>	27642707	<i>Dated 12/04/10 4:24 pm, Page 1 of 7</i>
<i>Client Reference</i>	gdeeb001	<i>Register Only</i>

Figure 4.7.1: Property Title

4.7.1 DEPOSITED PLAN

Identifier

NA121D/310

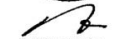
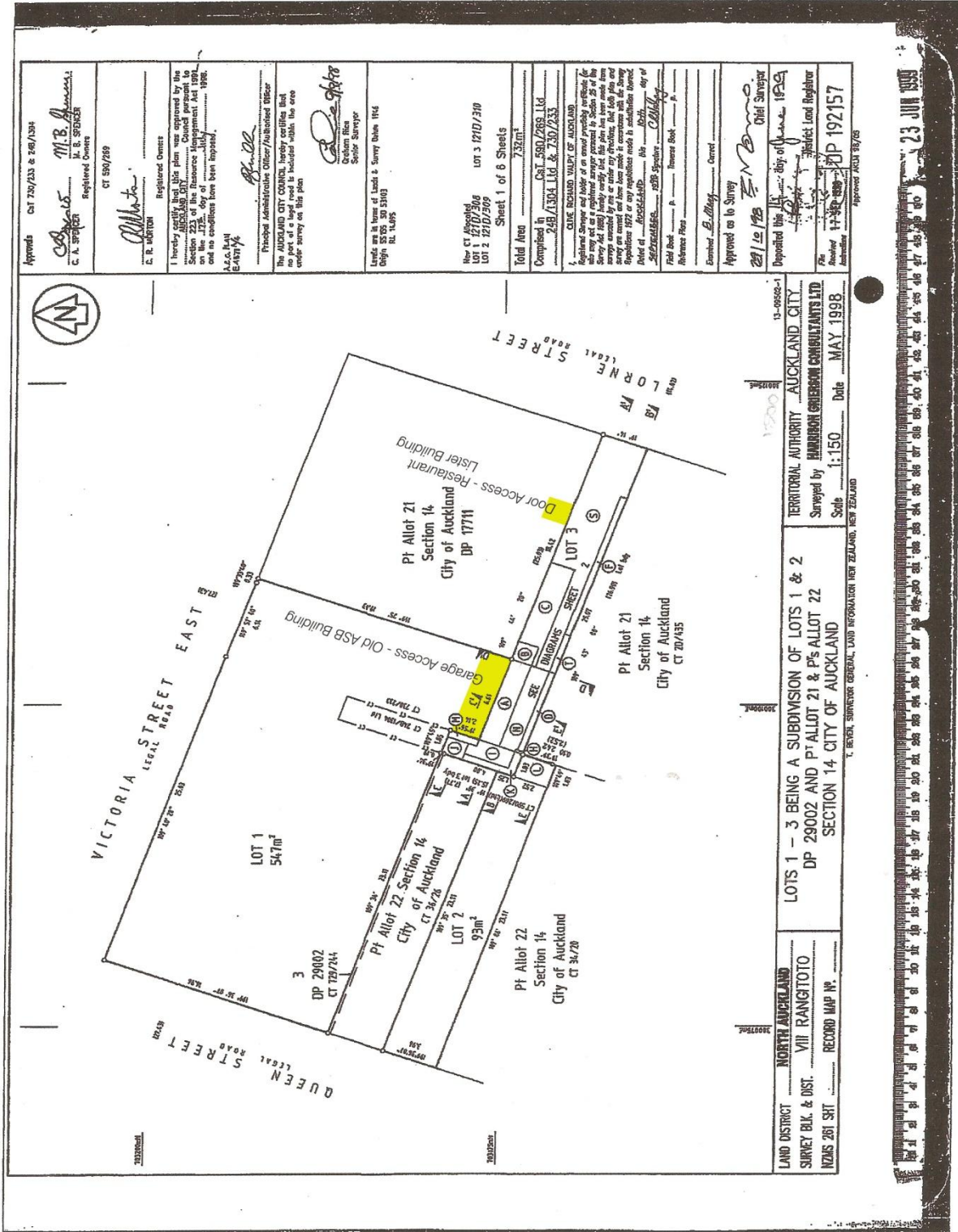

Figure 4.7.2: Deposited Plan (Lot 3 is an independent property owned by the Spencer's which means that it is not necessary to sub divide the property and obtain a separate title to the land as this is already in existence)

4.8 SITE PHOTOS

LOT3 SERVICE LANE / LORNE ST



Figure 4.8.1: Service Lane Photo
Left is Historic No3 / Right is Historic No 9-17



Figure 4.8.2: Site Model 1:500 Photo

4.9 SITE CONTEXT

Lot 3 site is surrounded by a diverse range of densely populated buildings existing on Lorne St. Their height ranges are between 7.5m to 28m and most buildings fall within 2-6 floors. A mixed use heritage building to the north - otherwise known as the Lister Building, built in 1924-1925 for commercial dental and surgery rooms. A heritage book store and café is to the south. The old AMP building to the north-west which was built in 1962 by architects: Thorpe, Cutter, Pickmere & Douglas (design architect: Jack Manning) being Auckland's first curtain walled office building. Commercial buildings situated to the west and apartments to the east. Lorne Street's retail and café space is most common on ground floor.

4.9.1 LOCAL AUTHORITY INTENTIONS FOR HERITAGE BUILDINGS / SITES

ARCHITECTURAL CHARACTER INTENTIONS

- “Maintain facades if sufficient heights in Lorne/High St to enclose the street, offset by an emphatic rather than progressive setback above that height”.²⁸
- “Ensure the development is designed in a sympathetic and sensitive manner to enhance and complement the existing qualities, both at street level and above”.²⁹
- “Ensure that, as far as possible, aggregate vehicle and service access provisions does not interrupt street frontage”.³⁰

HERITAGE BUILDING SITES

- “Promote the recognition and description of those buildings in the area of architectural, historic and streetscape significance”.³¹

CHARACTER ELEMENTS OF AREA

- “An Abundance of multi-level retail activities, basement and ground”.³²
- Windows generally expressed as punctuations in solid walls – the solid to void ratio is high.
- Small human scale to shop fronts and recessed entrances, providing transition from outside to inside. Some recessed whole shop fronts are successful in creating ‘pause spaces’.
- The narrow original lot subdivision gives rise to a diversity of buildings, architectural treatments and functions.

²⁸ Auckland City Council, (2004) Annexures, Volume 4, 51

²⁹ Auckland City Council, (2004) Annexures, Volume 4, 51

³⁰ Auckland City Council, (2004) Annexures, Volume 4, 51

³¹ Auckland City Council, (2004) Annexures, Volume 4, 51

³² Auckland City Council, (2004) Annexures, Volume 4, 51

5.0 ANALYSIS OF SITE EASEMENTS

PROPERTY OWNERSHIP

In Consultation with Lawyer George.D Barrister and Solicitors (refer to appendix for Consultants Log).

1/ Pedestrian Right of Way

2/ Projection Right

3/ Service Easement

4/Light Well Easement

5.1 EASEMENTS DEALT WITH BY DESIGN

PEDESTRIAN RIGHT OF WAY

Access to the Lister building's southern entrance to the Old AMP building's garage at the back of the site has been maintained through design. Pedestrian right of way is still maintained and as a result infill occupant car parking may be rented from the old AMP building, through a monetary negotiation which is now a rental car company (corner of Queen and Victoria East St). Therefore car parks are accessible at the back end of the site.

SERVICE EASEMENT

At ground level a service van is able to access neighbouring services at the back of the site. The Lister building inspection points on the southern façade are made accessible by raising the building (refer to figure 5.2.3 for services locations).

LIGHT WELL EASEMENT

A translucent double glazed façade comprising of a fire rated glazing (Borosilicate glass and intumescent coating specified as – 60/-)³³ cladding the northern façade of the infill, allowing the infill and Lister building to effectively share light. Objects viewed from behind this façade will be read as obscured shadows behind a glowing screen. Natural day light will be distributed through the 6m X 3m central light core and tunnelled through the infill from street frontage direct/daylight.

³³ Johnson Mark, S. N. L. "Why Fire Rated Glazing?" 1 – 3

5.2 LAND OWNERSHIP AND PROPERTY ASSUMPTIONS

For this infill project to be viable, a number of assumptions have to be made. These are listed below.

OWNERSHIP OF LAND

The land in question, namely Lot 3 on the deposit plan 192157 is owned by the client, or at least he has a right to, and is able to acquire the land for the development on which it is to take place.

RESOURCE AND BUILDING CONSENT

That the client has applied for and obtained the necessary resource and building consents for the project, and that the land in question is zoned for the proposed development. I see this as being a process to be undertaken by a town planning consultant with the necessary expertise.

TITLE ISSUES

The property is subject to:

- Pedestrian right of way over parts marked 'B'C'F'R'S and T and to;
- Projection right over parts marked 'B' and 'C' on the Deposit plan 192157.
- A light well easement over part marked 'H'K'P'Q' and 'R'
- A right of way and service easement over parts marked 'A,B,C,D,F,H,I,K,N,P,O,R,S and T.

CLIENT RELATIONSHIP AND PAYMENT

As stated in the above land ownership, it is assumed that the client is the owner and has the right to acquire the strip of land, has had the particular easements surrendered and that payment for the project will not be an issue. The terms of payment will be set out in a 'letter of engagement' with the client to ensure that payment is received.

VIABILITY OF PROJECT

It is assumed that the client has carried out a feasibility study on the project and is satisfied that it is commercially viable.

AIR RIGHTS

It is assumed that the client is able to obtain air rights over the southern neighbour through a monetary agreement. Payment would be made per square metre covering an area of approximately 100m².

5.3 SITE RESTRAINTS

LISTER BUILDING

SERVICES / ACCESS

Lot 3 is a standalone property owned by the 'Spencers' who also own the Spencer on Byron (refer to deposited plan figure 4.7.2). However this development does impact the northern neighbour which happens to be the Lister building. Although building in the city can be brutal this development takes into consideration the most effected neighbours. As a result it incorporates translucent facades and light cores on the northern side.



Figure 5.3.2: Diagram of Lister Services, Access Points (Yellow) and Inspection Junctions (Red)

6.0 DESIGN PROCESS

6.1 FUNCTIONAL ORGANISATION

BUBBLE DIAGRAMS

Through various spatial diagrams, the internal spaces evolved and the best relationships in accordance with the client briefs were, in the end established.

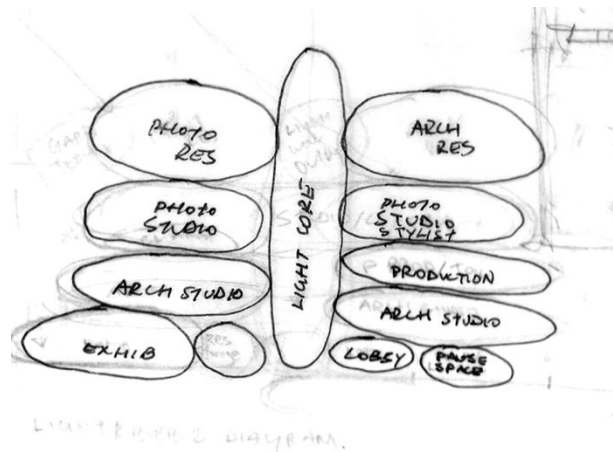

Figure 6.1.1: Sketch showing **initial** functional stack

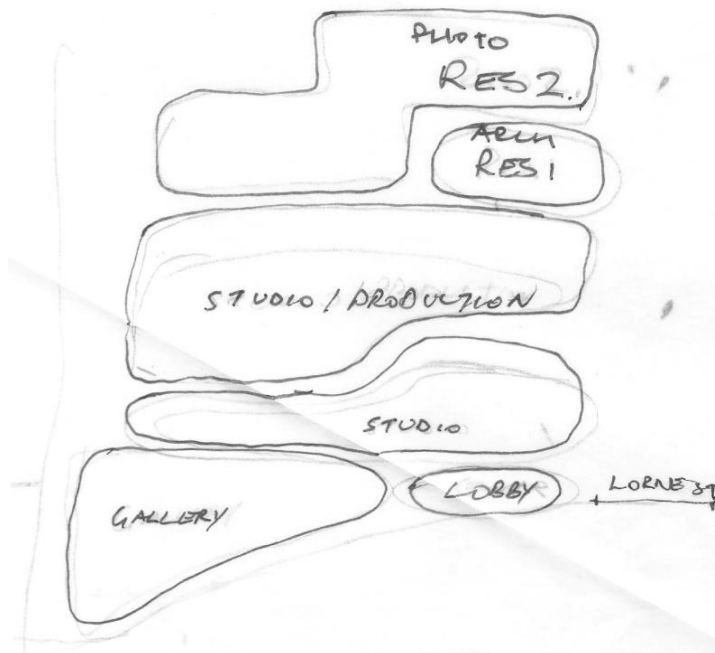

Figure 6.1.2: Sketch showing a **developed** functional layout with gallery

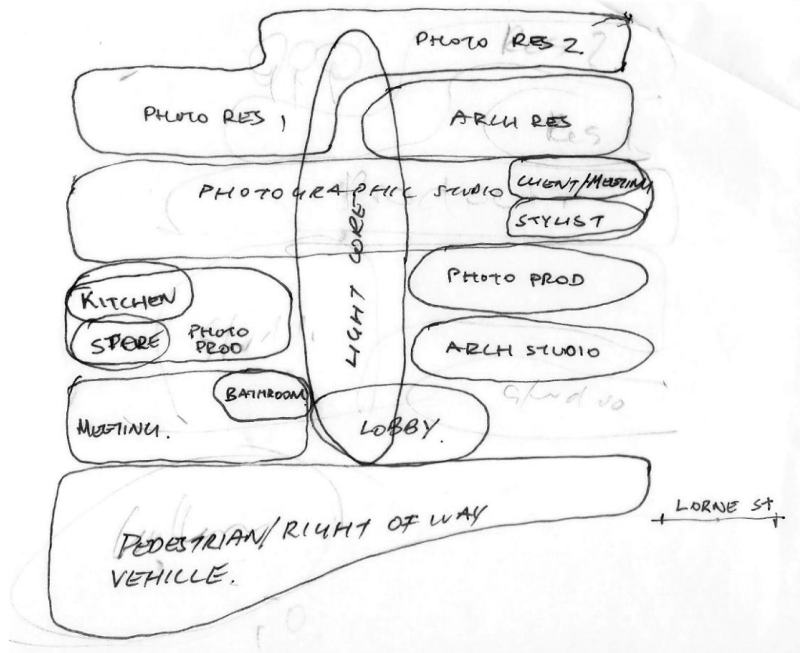

Figure 6.1.3: Sketch showing a final functional organization with pedestrian right of way.

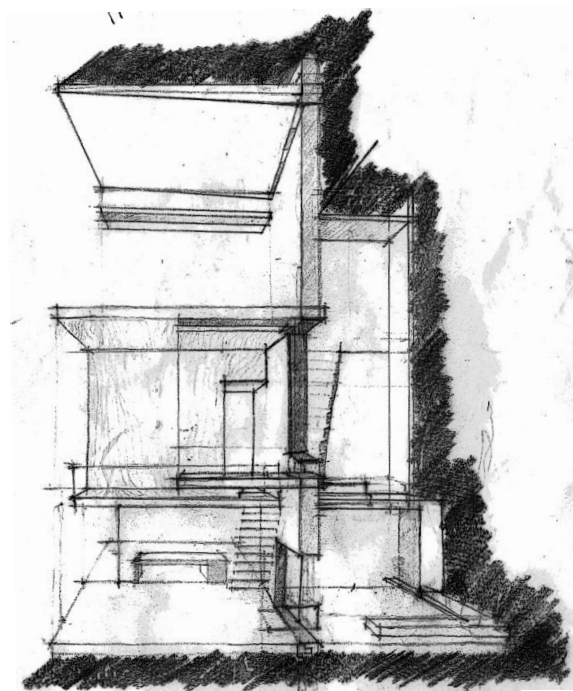

Figure 6.1.4: Sketch showing basic function organization.

6.2 SPATIAL LAYOUT

During the design process one of the main leaps was going from the layered floor plate design (below) to a staggered arrangement of floor plates and levels.

The staggered effect enhances spatial quality, accommodates the clients requirements and takes advantage of natural light distributed from the central core, street frontage and rear light well, situated at the back of the site. This creates spaces of intimacy and openness, eliminating the long corridor effect and improving the spatial relationships between linked spaces.

“Long thin rectangles, increase the separation between these places inside the building and therefore increase the relative privacy which people are able to get within a given area”³⁴

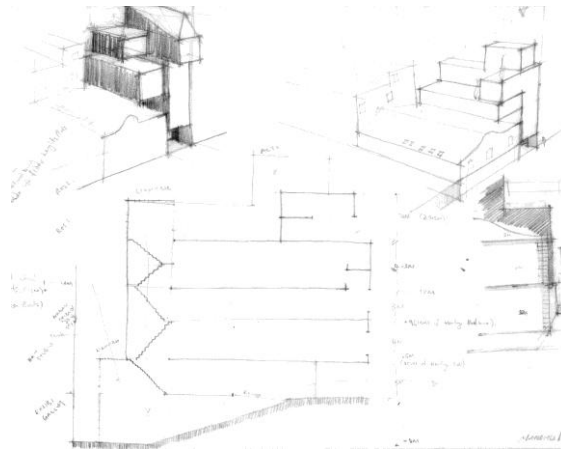

Figure 6.2.1: Initial spatial arrangement with core situated at back of site

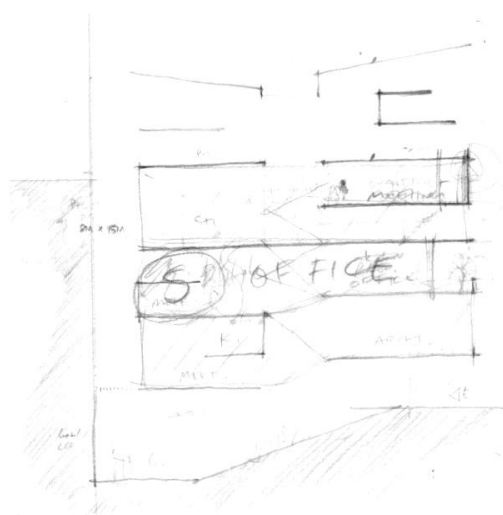

Figure 6.2.2: Developed arrangement, centralizing core for a better distribution of light and circulation.

³⁴ Alexander, C. (1977). "A Pattern Language Towns, Buildings, Construction". New York, Oxford University Press, 536

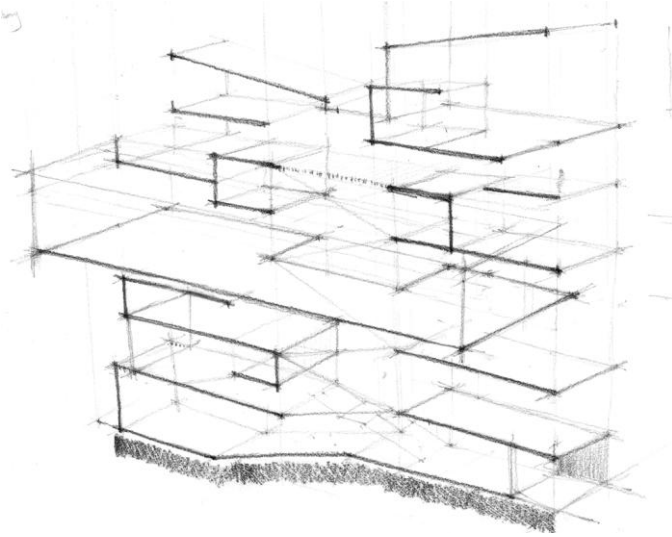

Figure 6.2.3: Axonometric view of developed arrangement

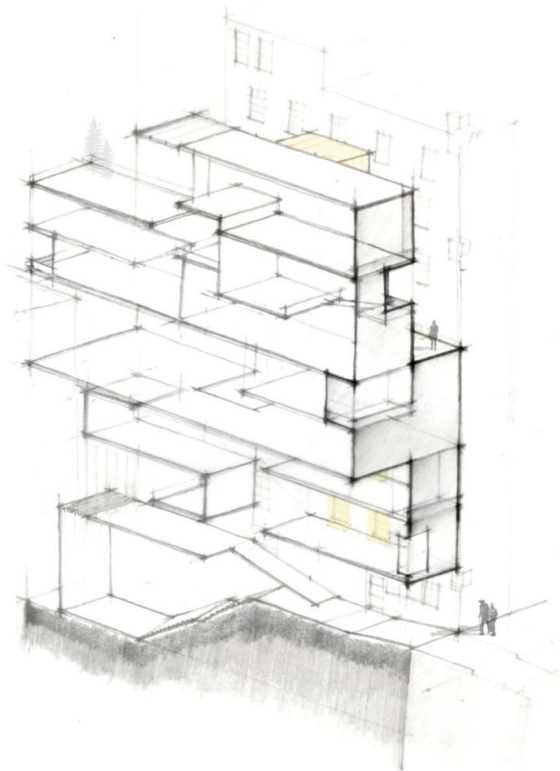

Figure 6.2.4: Final spatial arrangement with gallery space which is now a pedestrian right of way

6.3 CONCEPT / FORM

The form derived mainly from clients' requirements, site restraints and the intention of optimising day lighting and solar gain if possible. Resulting from this came the shift in an ordinary "straight up and down" rectangle to a Tetris-like³⁵ infill shape. This form proved to meet the client requirements and aesthetic standard. This shift in the final concept involves the exploitation of airspace of the south neighboring building of four metres. This form opposed to the generic, provides more light to enter the upper spaces of both the infill and neighboring Lister building.

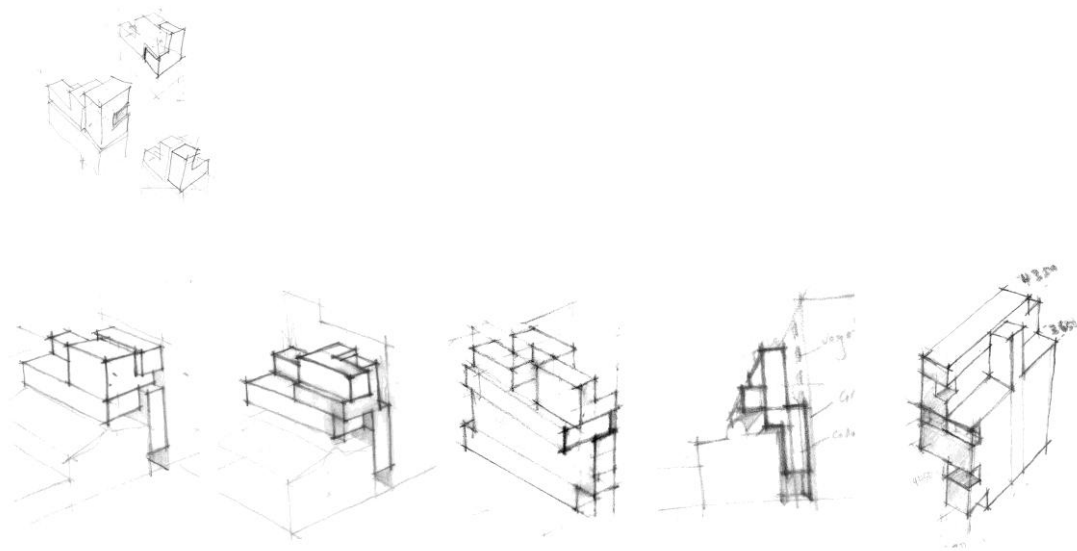

Figure 6.3.1: Concept Development Sketches

³⁵ Tetris is a basic computer game involving various shapes which came out in 1984. The idea resembles a Tetris infill of the city representing ongoing urban densification.

6.4 STRUCTURAL SYSTEMS

The first structure was two high precast walls with floors infilled in between. Two vertical walls with infilled floor slabs developed into one larger structural spine, steel core and cantilevered floor slabs with diagonal steel tensioners.

The final structural system which is a more elegant refinement is made up of an in situ concrete spine of 500mm, with hollow concrete cantilevered floor slabs and a steel structural core for lateral support. The end result is a building with its structure only occupying 2/15 of the site, while keeping the main functions of the service lane in operation and maximising internal space. Therefore, allowing the rest to be used for the live and work requirement of the clients.

All structural systems were designed with concrete in mind to help blend with the immediate heritage masonry buildings. Exposure of the structure is intended, to help the occupant realise how the building they occupy is constructed.

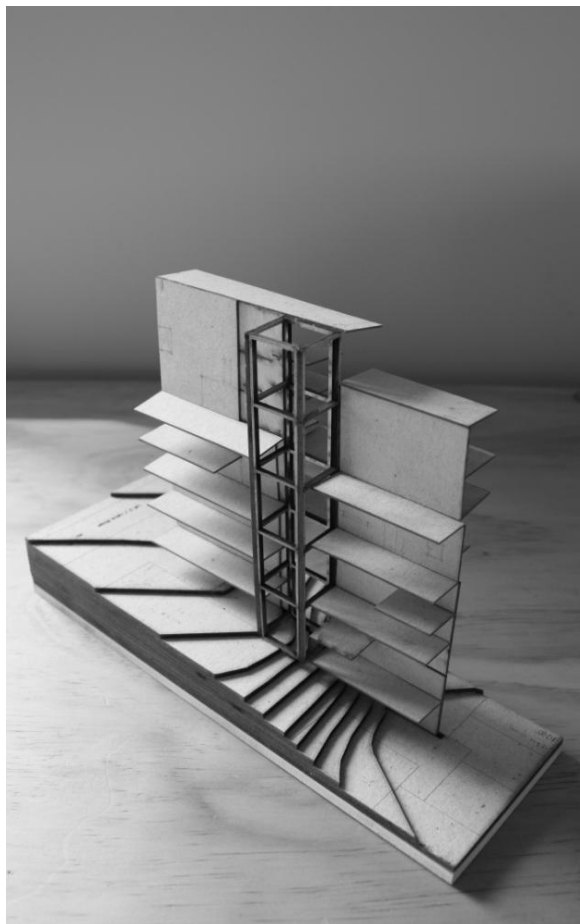

Figure 6.4.1: Structural Development Model

6.5 SPINE AND FLOORS

The structure exists as a 500mm in-situ spine on a pile driven foundation, with cantilevered precast slabs.

Secondary to the central spine are the aesthetically tapered hollow concrete slabs.

The steel reinforced spine is comprised of plumbing, electrical and heating services which peel off and feed into the hollow sections of the floor slabs.

The slabs are almost the same width as the spine at their connection, tapering out, becoming thinner and lighter. This allows some spaces to be more intimate than others. The slab's brackets integrate a rebated lighting slot lined with steel.

A steel core is situated in the centre of the building housing the circulation and providing lateral support.

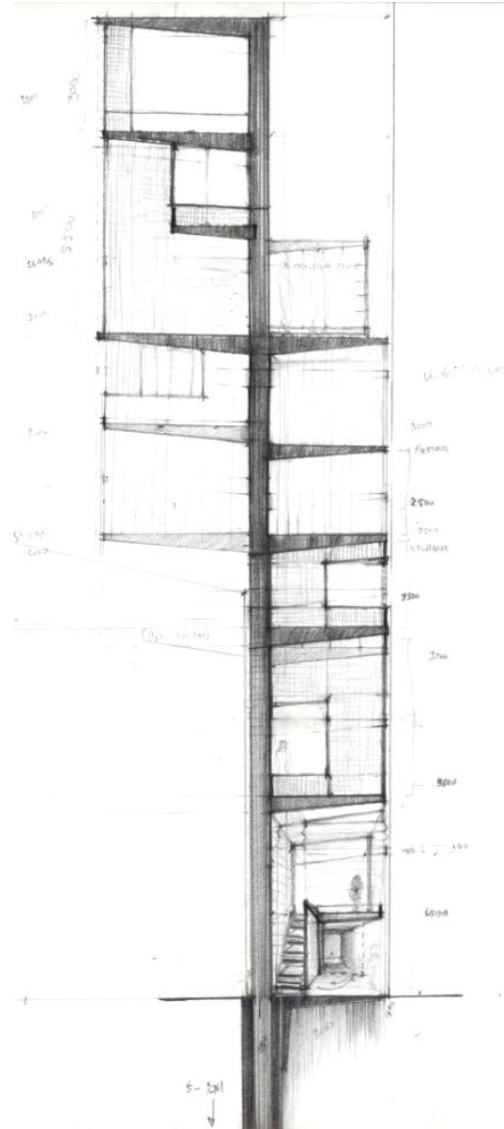

Figure 6.5.1: Section Showing Hierarchy of Elements

Tectonic expression testing occurred in places where there was an exposed slab to spine joint, achieving an interlocking pattern effect. However, in consultation with Hamish N, the structural engineer, this structural pattern expression, was not possible with concrete cantilever construction. Therefore a more continuous method was implemented. This comprised cantilevering floor slabs off the spine, with a continuous topping slab running into the spine - knitting the two together creating the cantilever - expressed on the street front facade.



Figure 6.5.2: Expressive Slab to Spine Concept Model

Alternative floor types were considered such as; standard concrete slabs supported by diagonal steel tensioners - this proved to be an obstruction in most spaces. Steel floors and spine were considered, however surrounding context utilised masonry and therefore suggested the use of concrete.

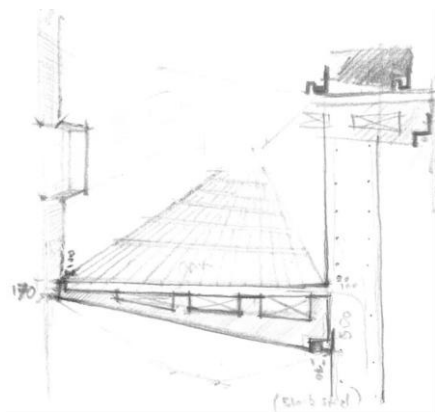

Figure 6.5.3: Sketch Detail of Tapered Slab to Spine

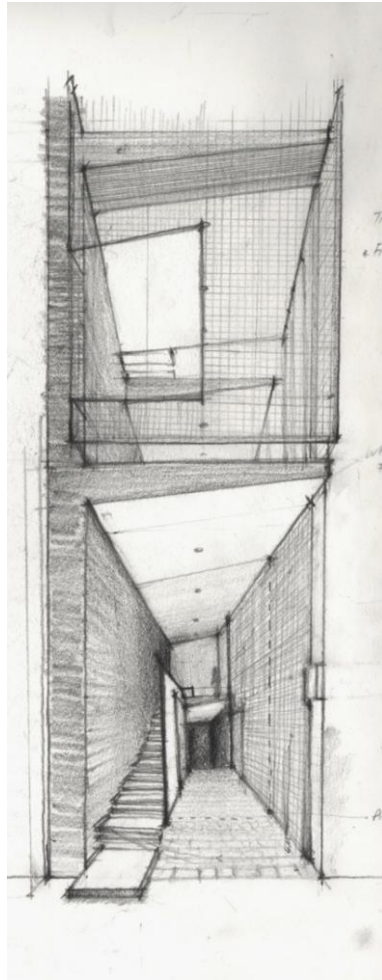

Figure 6.5.4: Entrance Sketch Showing Meeting of Spine to Slab

6.6 MATERIALITY

SOUTH / WEST AND STREET FRONTAGE FACADE

The exterior of the commercial studio is cladded with cedar timber slatting. The comprehensive use of this cedar cladding differentiates the commercial from residential occupancies.

NORTHERN FACADE / FIRE PROTECTION

Exterior glazing involves Borosilicate glass and frame tested to a fire rating of -/60/- (this measurement indicates the length of time in minutes the glass and frame has been tested to physically stop the path of the fire)³⁶.

The fire rated glazing unit is Insulated with Krypton gas infill (highest insulation value).

Internal glazing is sand blasted and toughened for safety. Sand blasting the glazing gives an opaque grainy effect, giving figures behind this facade an obscured shadowy appearance.

This is done for privacy and exists in commercial spaces.

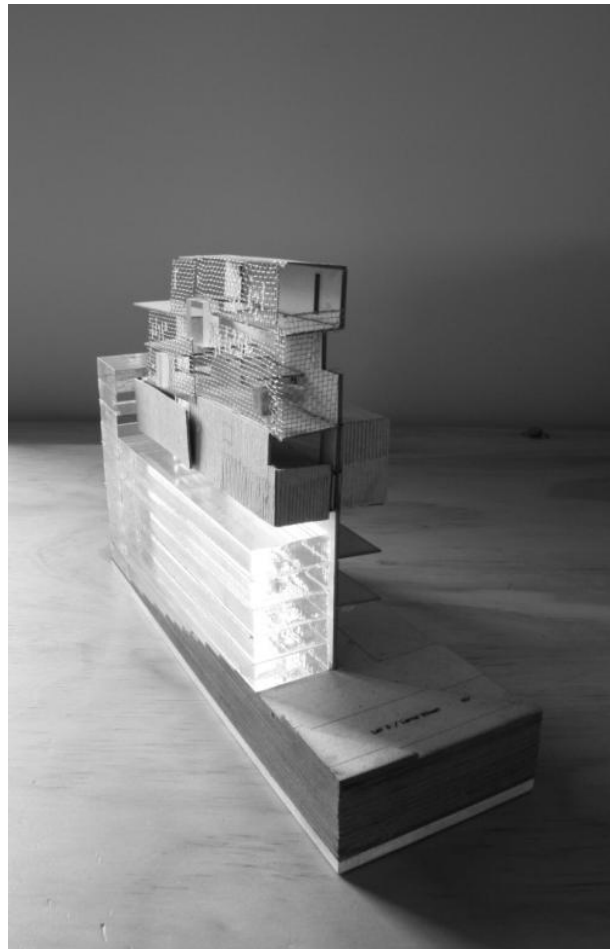

Figure 6.6.1: Conceptual Model Showing Materiality

³⁶ Johnson Mark, S. N. L. "Why Fire Rated Glazing?" 1 – 3

7.0 CRITICAL APPRAISAL AND CONCLUSION

The question posed in the outset of this project, was whether or not an urban service lane could be transformed into a viable live and work space for two clients - a photographer and an architect. Four objectives were established and through the design process I have determined whether or not these are viable.

MEETING THE BRIEF

The first objective is to meet the briefs of a live and work space for two clients - the limitation of which was the confined site located in the urban service lane on Lorne Street. I am satisfied that the end result of this design has successfully created an aesthetic and integrated solution to both client's live and work requirements.

ENHANCING THE SPATIAL EXPERIENCE

The second objective is to enhance the spatial experience through structural expression. Maximizing the use of space within the confines of a service lane was a significant challenge. The tree-like structure maximizes the buildings spatial capacity. The structural method and its expressive construction and honesty to materials successfully creates a richer internal experience for the occupants.

INTEGRATING SUSTAINABILITY

Objective three is the integration of sustainability. I feel the final design has successfully managed to integrate active and passive sustainability systems. The formal qualities have attempted to maximize solar gain potential however, the site and surrounds places limitations on the access to direct sunlight and therefore limits the passive thermal massing system.

A VIABLE MODEL?

Objective four explores whether this development is in fact a viable model for future infill in New Zealand. Not only did the success of the design determine whether this could be used as a model, but I also had to determine whether such a model would be commercially viable and consider broader site constraints.

Considering the site constraints - Auckland City was well planned and surveyed accurately in the late 1840's which gave the city a good base for today's planning and construction. This has left very little 'left over space'.

The project has not been without difficulty and the selected service lane site posed many unexpected challenges, such as, dealing with land ownership, property and easement issues. Design challenges were also difficult to overcome, such as dealing with immediate neighboring buildings. The reality of building in the city, more so, building on a confined site is quite brutal. However, best efforts and design intentions have considered others on which the development impacts.

In order for the project to be commercially viable an investor would be looking to make a return on the money invested in the acquisition of the land and construction of the building around 10% or 11% per annum on the sum invested.

The capital investment will include the cost to purchase the land, the construction costs of the building, architectural and legal fees, surveying fees and development contribution to the Auckland City Council.

A hypothetical example of these costs will be as follows:

- Land value of 105sqm at approximately \$1,000 per sqm = \$105,000
 - Cost of construction including architectural fees: \$3500 per sqm x 810 sqm = \$2,835,000
 - Legal fees: \$10,000
 - Development contributions to Auckland City Council approximately \$30,000 for the development.
- Total of \$2,980,000**

In order to justify the development from an investor's perspective the project would need to realize a return of 10%, being nearly \$300,000 per annum at 10%.

On these figures, the proposed development is not commercially viable. However the clients are well aware of this and have stated that it is not essential that the project be commercially viable as their reasons for entering in the development are as follows:

- The location
- The profile the client would receive of owning a unique development being the only of its kind in Auckland City and for that matter New Zealand, which is seen as essential to promote their high profile in the industries in which they work.

Given these reasons it is assumed that the clients are willing to proceed.

This project demonstrates that a live and work building design to infill a service lane is possible. However the site constraints and commercial viability suggest that this would be a difficult model to implement on a large scale, due to it being so site specific.

8.0 BIBLIOGRAPHY

Alexander, C. (1977). "A Pattern Language Towns, Buildings, Construction", New York, Oxford University Press.

Auckland City Council, (2004) "Annexure", Volume 4.
<http://www.aucklandcity.govt.nz/council/documents/central/annxures.asp>

Bow-Wow, A. (2010). "Auckland Architecture: A field Guide", The Broadsheet of the Auckland Branch of the New Zealand Institute of Architects (July Issue): 3, 4.

Frampton, K. (1995). "Studies In Tectonic Culture: The poetics of construction in nineteenth and twentieth century architecture", Chicago, Graham Foundation for Advanced Studies in the Fine Arts.

Hadid, Z. (1986) "Office Building on KURFURSTENDAMM 70".
<Http://www.zaha-hadid.com/offices-and-towers/office-building-on-kurfurstendamm-70>

Johnson Mark, S. N. L. "Why Fire Rated Glazing?" 1 – 3.
<Http://www.fireprotection.org.nz/publications/Website%20Why%20Fire%20Rated%20Glazing.pdf>

Kishi, W. (1992) "House in Nipponbashi".
Http://k-associates.com/k.associates/en/03_works/residence/residence.php?id=12

Morse, M. (2002). "Skybox", Home and Entertaining, 56.
<Http://www.mellingmorse.co.nz/skybox.htm>

North Shore City Council, (2005). "Good solutions guide for mixed use development in town centres", [Takapuna, N.Z.]: North Shore City.

Stang, A. (2005). "The Green House: New Directions in Sustainable Architecture", New York: Princeton Architectural Press; Washington, D.C: National Building Museum.

Walker, C. (2005). "Exquisite Apart: 100 Years of Architecture in New Zealand", Auckland, N.Z, Balasoglou Books on behalf of the New Zealand Institute of Architects.

9.0 APPENDIX

9.1 CONSULTANT LOG

HAMISH.N STRUCTURAL ENGINEER

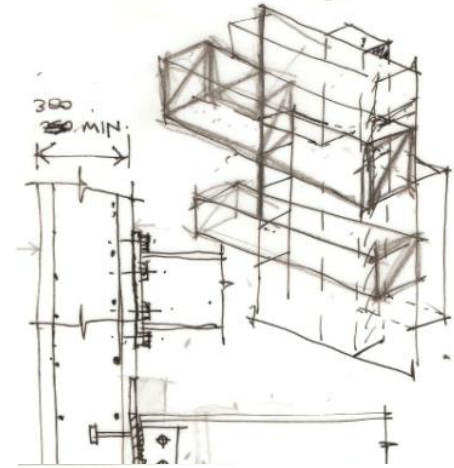
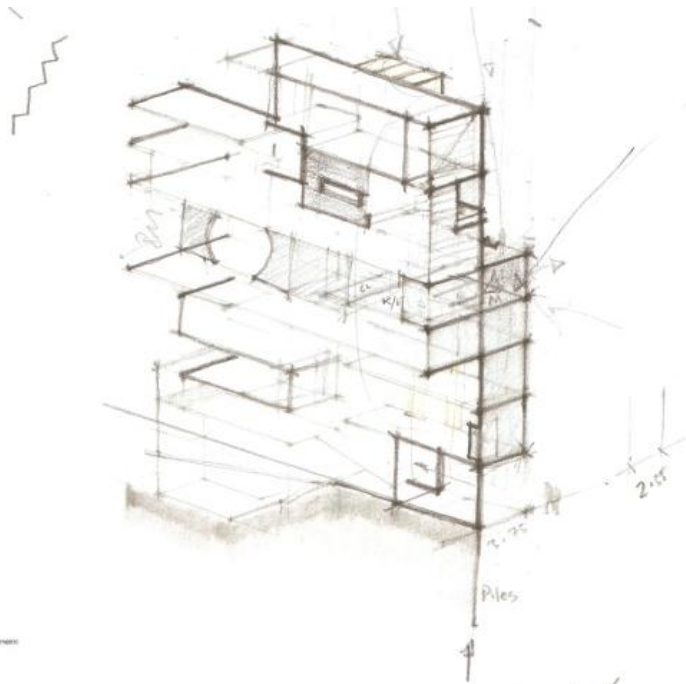

* SPREADSHEET: HAMISH.N 22.08.2012

part ✓
part x

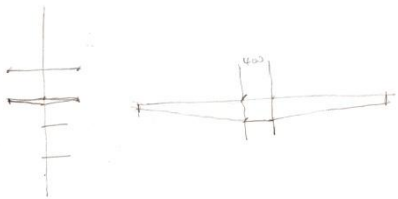

4 columns @ 4mm

6m cantilever

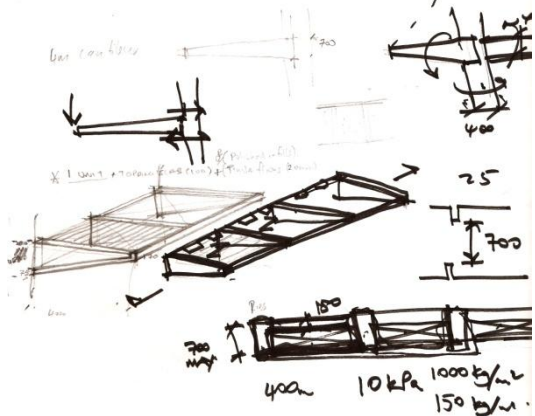

400 10kPa 1000kPa 150kPa

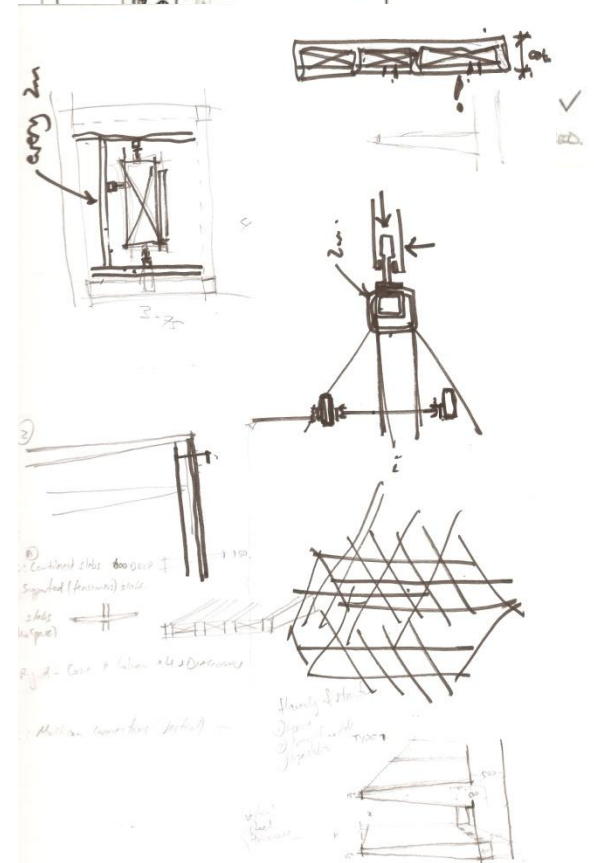

Consider this 4000kPa
Suggested (Assumed) steel
slabs
width
By d = 400 + 200 = 600
Main members steel -

Handy of the
Dept of
Structural
Engineering

9.2 CLIENT CONVERSATION LOG

NATHANIEL.C ARCHITECT

From: Matt Deeb [mailto:mattdeeb@hotmail.com]
Sent: Sunday, 24 January 2010 2:59 p.m.
To: Nat Cheshire
Subject: Hi Nat its Mat

Hi Nat

It would be great if you have time to write a short brief which I will probably use in my masters proposal- on the requirements of a "live and work" situation.

Attached is my proposal and highlighted is my uncle Nadav's brief for the same situation.

The basic question for the proposal is to design a "live and work" mixed use development for an Architect and Photographer (possibly a lawyer to if the project needs to be bigger, but I'm sure these two types of people would gel much better).

Cheers

Matt

From: [Nat Cheshire](#)
Sent: Monday, January 28, 2010 11:37 AM
To: [Matt Deeb](#)
Subject: RE: Hi Sir Nat

Hi Matt

Lots of natural light and a place to curl up and read in the sun. Two places to sleep that accommodate two people each and that are separate in some way from each other and an eating, cooking and sitting spaces.

A single bathroom only but with somehow separable WC and cunning double-entrance so can be accessed from both public side and bedroom.

Smart kitchen open to the sitting and eating spaces that is robust and designed for cooking not slickness – hanging implements etc – with a place for everything.

A small decompression space between outside and in – so that the sitting etc is not immediately visible from the front door, and there's a place to take off coats, stack umbrellas etc

A fluid plan that has a minimum of doors. No TV. Plenty of bookshelves, wardrobes, storage integrated into fabric of building – perhaps no walls at all only cabinetry (although the 'verso' side of that cabinetry should be like a good wall – robust absolutely uninterrupted to facilitate good art hanging).

I don't want to see power points, light switches. No trims/skirtings/architraves plonked on top of junctions in typical kiwi fashion. If in the city prefer to live at least a storey above the street, so preferred stack from ground up is cars – studio – apartment – roof garden; and if the site is right perhaps food/bev/retail to street level.

Large more-or-less private (i.e. a skyscraper overlooking is ok but not an immediate neighbour) garden/terrace with proper trees either a/opening off sitting/eating space or b/roof garden opening off a small study/reading room or c/both.

Studio large open space 100~200m² empty light and pale with something to conceal guts (print, copy, model gear, storage) and some part that can be made private for meetings. No reception.

Materials should not be expensive – I am happy with humble materials well treated so as to become very special.

Good clear forms important – not too many ducks and jives.

Cheers

Good luck

Nat

From: Matt Deeb [mailto:mattdeeb@hotmail.com]

Sent: Wednesday, 3 February 2010 9:14 a.m.

To: Nat Cheshire

Subject: Re: Hi Nat its Mat

Hey Nat,

If you have time this week, send me through your version of requirements/needs for a "work from home" situation (within a mixed-use complex in the city).

Kind Regards

Matt

From: Matt Deeb [mailto:mattdeeb@hotmail.com]

Sent: Wednesday, 3 February 2010 9:14 a.m.

To: Nat Cheshire

Subject: Re: Hi Nat its Mat

Hey Nat,

If you have time this week, send me through your version of requirements/needs for a "work from home" situation (within a mixed-use complex in the city).

Kind Regards

Matt

From: [Nat Cheshire](#)

Sent: Monday, March 08, 2010 11:37 AM

To: [Matt Deeb](#)

Subject: RE: Hi Sir Nat

Dimensions: I give studio 100-200 sqm but this need not be entirely on one floor....could be split some way to delineate different activities.

Living dining cooking space should be 40m2 minimum.

Feel free to tighten things up a bit and make a new proposition based on a tighter site.

Good luck

Cheers

From: Matt D [mailto:mattdeeb@hotmail.com]
Sent: Sunday, 14 March 2010 6:56 p.m.
To: Nat Cheshire
Subject: Lorne Street Site

Hey Nat

I've done some trial designing on butter paper for the Lorne street site, which I really like. Although, I think the program/requirements that I currently have are too large for the site. I like the idea of building vertically and then maybe cantilevering across, however there is a conflict with the heritage building on the left. I have a feeling the heritage building facade may have aesthetic conflicts with the cantilever or building going over. The site is less than 3.8m in width due to the heritages exterior decoration and services of the neighbouring building (heat pumps). So realistically, useable interior building space would amount to about only 3m including walls etc which is find is too small, underground parking is also an issue but maybe possible with stackers and turntables but width for these services are still an issue.

So at this stage I'm keeping the Lorne street site in mind but keeping an eye open for other sites, or rundown buildings in cavity sites which could be demolished.

Matt

NADAV.K PHOTOGRAPHER

Sent: 05/10/2009 22:28

To: "Nadav Kander"

Subject: Brief

Haven't spoken in a long time, hopefully electronic communication will do the trick!

I was wondering if you would be interested in being my client for my final master's project next year. A brief intro to the project is, for me to create my own architectural problem and solve it through a design process next year, producing a full design.

My working title is: To design an urban 'work from home' dwelling for a photographer and his family within a cavity in the fabric of inner Auckland city.

It would be fantastic if you could write a client type brief in terms of what a professional photographer requires as a work/office space. Keeping in mind your living quarters will be within the same dwelling (possibly above).

I welcome your creative ideas and anything else you would like to add (your name).

I would really appreciate your feedback and hope you can assist me briefly with this project.

Best Regards

Matt

From: "NK" <nk@nadavkander.com>

Sent: Date: Mon, 19 Oct 2009

To: "Matt Deeb" <mattdeeb@hotmail.com>

Subject: Brief II

Hi,

Really sorry I didn't get back to you sooner I've been in NY for the week.

Id love to do this can it wait till I'm back. I could do it on the plane in 2 days time

What would help is questions to guide my brief. Tell me as much as you can what you'd expect the form or format of my brief to be.

Nadav

From: Matt D <mattdeeb@hotmail.com>
Date: Thu, 22 Oct 2009 17:34:27 +1300
To: Nadav Kander <nadav@nadavkander.com>
Subject: RE: Brief

Hi Nadav,

Regarding the questions to guide the brief are listed below:

What would you expect the spaces to be like in terms of physical requirements, how big? And the relationships between them, e.g. studio and reception, toilets, dark room (connectivity of spaces in terms of sightlines into other spaces..Maybe to keep an eye on your clients or your kids in the residential quarter...

Also what image would you want your firm to present? This could be an aesthetic issue that would portray yourself to your clients...

Lastly, would you prefer a street frontage setup for your studio? You would be exposed and public could see what you do. Or more so enclosed/hidden away?

Cheers
Matt

From: Nadav Kander <nadav@nadavkander.com>
Date: Thu, 22 Oct 2009 17:34:27 +1300
To: Matt D <mattdeeb@hotmail.com>
Subject: RE: Brief

Hi Matt

Right here goes...

my studio needs to be at least 10 m x 15 m better would be 10m x 23m shooting space not necessarily day lit as I light most things. Height needs to be at least 4.5m. If an area was day lit this could be curtained off and used as a client area with sofa, chairs and a computer and possibly a small freestanding kitchen for serving food and drinks, this area would be ok at 6m x 4m holding about 8 people comfortably, and carved out of the studio space. Separate to this would be a hair, makeup and stylist room same size as client room.

I would like another Store area for light s cameras and stands etc, it should be off the main studio and

be very secure and have a wide door to ceiling height. Toilet should be spa like with large basin and shower.

My office and production area needs to have 4 stations to work at. This is where daylight would be great very modern few materials e.g. Oak and concrete. This is where most of my time is spent and should look beautiful neat but understated. I wouldn't want This is where all the printing is done digital manipulation phone calls meetings and most meals are eaten

My studio at the moment has a day lit area of 10mx 10m dedicated to this and its ample. So an ideal situation would be storage cupboards on 3 sides including small kitchen and deep cupboards

Then 2 or 3 long wide desks 6m x 1.5m for 4 computers 2 people one side of one desk and another two opposite. The other 2 surfaces would be for eating and meeting and laying out papers and large prints.

Freestanding book shelves can be used to portion off an area let's say for meeting for e.g.

Toilets needed here or could share with the studio.

DON'T UNDERESTIMATE MY STORAGE NEEDS

More to come in a couple of days.

N

From: "NK" <nk@nadavkander.com>

Sent: Monday, March 22, 2010 11:34 PM

To: "Matt Deeb" <mattdeeb@hotmail.com>

Subject: Brief II

Hope this is enough

I imagine that my studio is connected to the home and only a secure door separates them although as said earlier the studio needs its own entrance. Most visitors to work won't be invited home and vice versa.

Our home brief would be best fulfilled if few materials were used. Glass is for windows not dividers or stairs. Concrete wood and stone are what we like. Fireplaces indoors always add a great feeling as do fires in outdoor living spaces.

Light is so important as we come from SA we feel more at home in light airy environments. Saying this it is also very important that this home be Eco friendly and economical to run. Systems to manage waste effectively and environmentally are important.

A large laundry room would be great and needs to be placed in a location where it makes sense i.e. why have it nr kitchen if it's predominately washing clothes housed in the bedroom. We do not need our kitchen to be separated from our dining area or sitting area however other rooms with TV and

internet are needed for soon to be teenagers who don't need to hang with their parents. No TV in Kitchen, bedrooms or communal area. Pls think about a lot of storage for coats rain gear shoes at the point of entry. I'm a keen biker (bicycle) and would like to store it indoors. Can you manage this so it's not just in the hall way on display.

The rest I leave in your capable hands to inspire us towards contemporary living and a ever changing family dynamic. Architects we aspire to Siza, Chipperfield, Barragan, Johnson, Mies Van Der Rowe.

Nadav

Final Project Drawings

Live and Work Infill
Street View Perspective

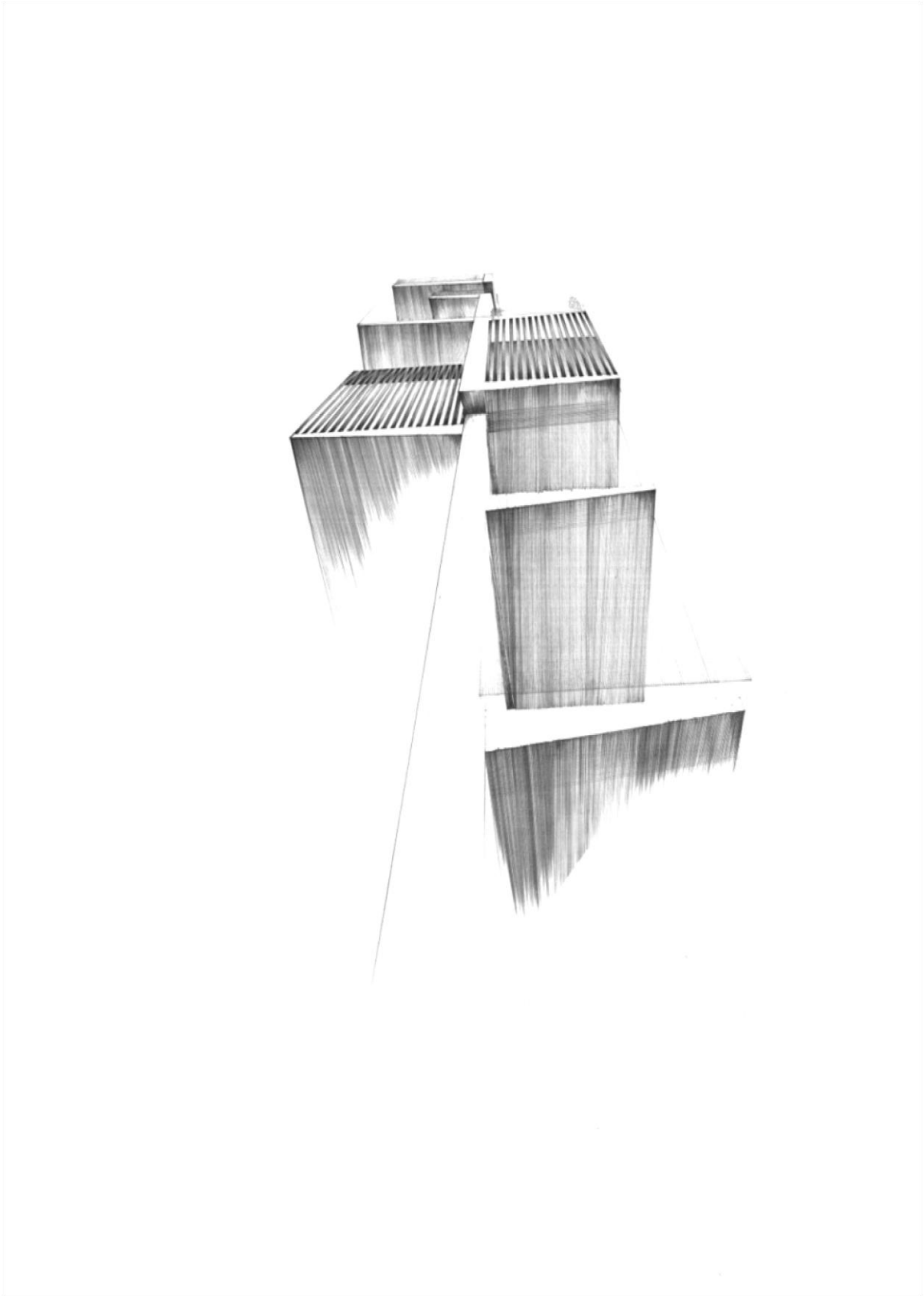

Live and Work Infill
Entrance / Lobby Perspective

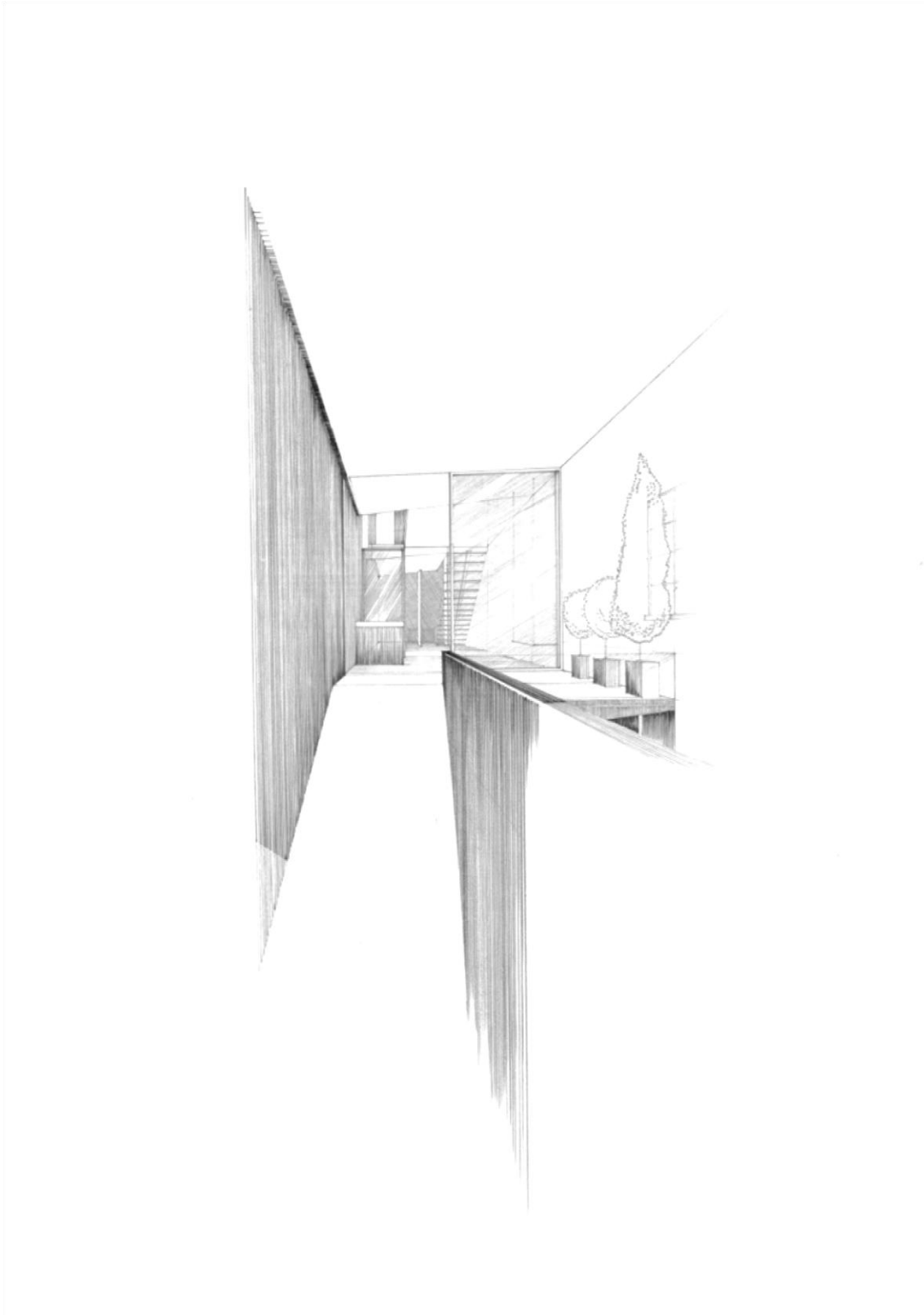

Live and Work Infill
Perspectival Section

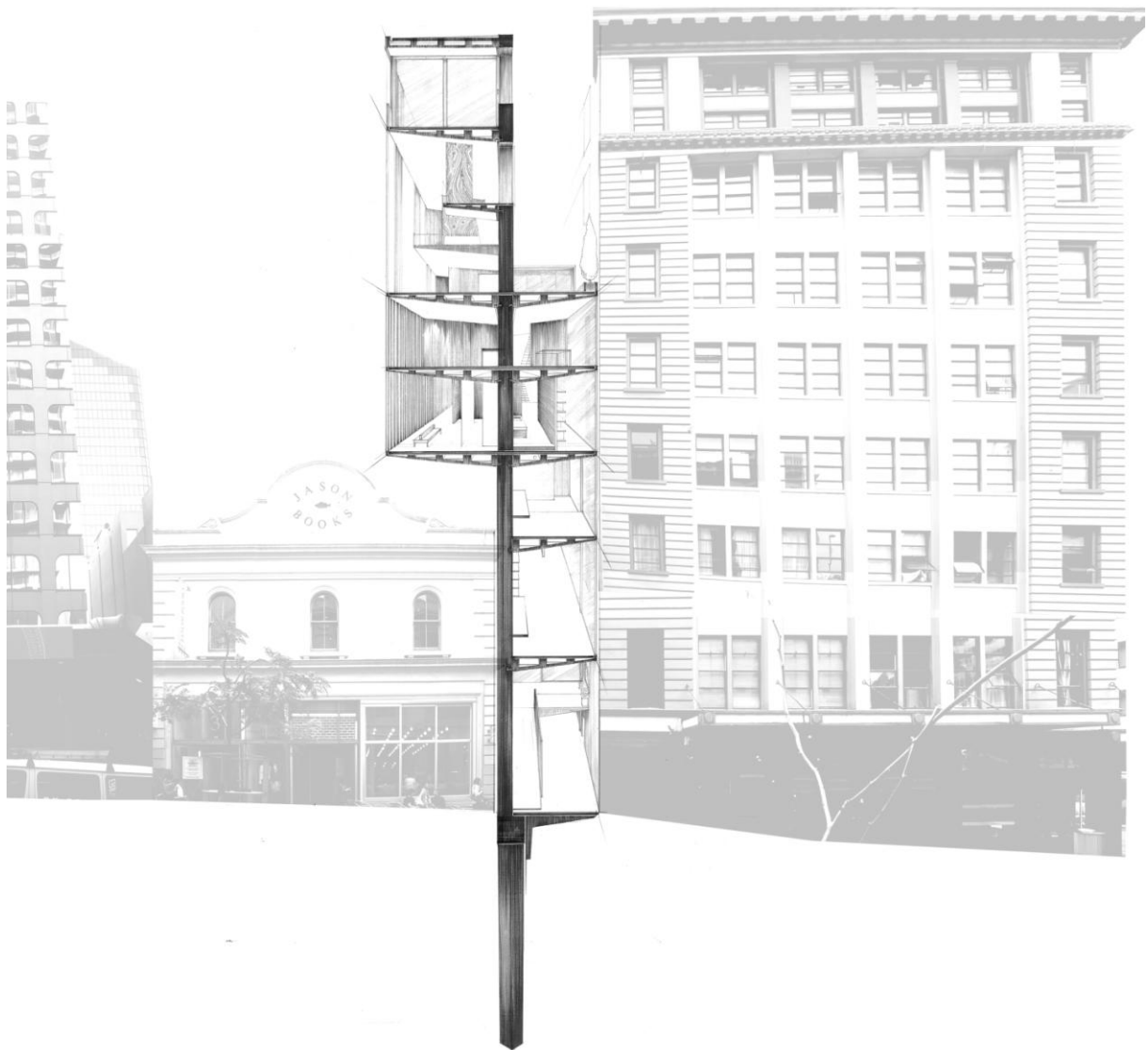

Live and Work Infill
Street Elevation



Live and Work Infill
Street Frontage Shot

